

HYDRAULIC TOWABLE AUGER



WARNING

READ AND UNDERSTAND THIS OPERATOR'S MANUAL COMPLETELY BEFORE USING THIS AUGER. ASSEMBLE, TEST AND USE ONLY IN ACCORDANCE WITH THE OPERATOR'S MANUAL INSTRUCTIONS.

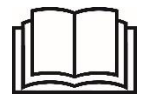



Table of Contents





- 1. Safety 3
- 1.1. Safety Precautions 3
- 1.2. Operating Safety 3
- 1.3. Mechanical Hazards 3
- 1.4. Fire and Explosion Hazards..... 4
- 1.5. Chemical Hazards..... 4
- 1.6. Noise Hazards 4
- 1.7. Protective clothing..... 4
- 1.8. Operator Safety using Internal Combustion Engines..... 4
- 2. Un-Crating and Assembly..... 5
- 2.1. Towbar Adjustment..... 5
- 3. Label Locations..... 6
- 3.1. Safety and Operating Labels 7
- 3.1. Safety and Operating Labels (cont.) 8
- 3.1. Safety and Operating Labels (cont.) 9
- 4. Technical Data 9
- 4.1. Specifications. 9
- 4.2. Dimensions..... 9
- 5. Operation 10
- 5.1. Operating Principle..... 10
- 5.2. Delivery Checks 10
- 5.3. Before Starting 10
- 5.4. Gasoline Engine 10
- 5.5. Adjustments 11
- 5.6. Attaching The Auger Bit..... 12
- 5.7. Auger Control 12
- 5.8. Handle Position 13
- 5.9. Swivel Lock..... 14
- 5.10. Digging 14
- 5.11. Moving Between Holes..... 15
- 6. Parts..... 16
- 6.1. Master Parts List 17
- 6.2. Handle Assembly 18
- 6.3. Engine – Pump Assembly 18
- 6.4. Tank Assembly 19
- 6.5. Valve Assembly 19
- 6.6. Motor Head Assembly 20
- 6.7. Towbar Assembly 21
- 6.8. Optional Tail Light Kit Assembly - GWG311009 21
- 7. Maintenance 22
- 7.1. Periodic Maintenance Schedule. 22
- 7.2. Air Cleaner 22
- 7.3. Spark Plug..... 22
- 8. Transporting 23
- 8.1. Prepare for towing. 23
- 8.2. Attach Towbar..... 23

1. Safety

1.1. Safety Precautions



Before using this equipment, study the operator's manual to become familiar with its operation. Do NOT allow un-trained or unauthorized persons, especially children, to operate this equipment. Use only factory authorized parts for service.

	This is the safety alert symbol. It is used to alert you to potential personal injury hazards. Obey all safety messages that follow this symbol to avoid possible injury or death.
 DANGER	DANGER (red) indicates that an imminently hazardous situation which, if not avoided, will result in death or serious injury.
 WARNING	WARNING (orange) indicates that an potentially hazardous situation which, if not avoided, will result in death or serious injury.
 CAUTION	CAUTION (yellow) indicates that an potentially hazardous situation which, if not avoided, will result in minor or moderate injury.
CAUTION	CAUTION (yellow) used without the safety alert symbol indicates a potentially hazardous situation which, if not avoided, may result in property damage.

1.2. Operating Safety



- Slip/Trip/Fall is a major cause of serious injury or death. Beware of uneven or slippery work surfaces.
- Exercise care when working in the vicinity of unprotected holes or excavations.
- NEVER allow any person to operate this equipment without adequate instruction.
- Ensure all operators read, understand, and follow the operating instructions.
- Serious injury could result from improper or careless use of this machine.
- Augers are heavy units and should be positioned by two people of appropriate strength.
- Use care when towing and never exceed 45MPH.
- Always turn the fuel shutoff to off before towing.

1.3. Mechanical Hazards



- DO NOT operate the machine unless all protective guards are in place.
- Keep hands and feet clear of rotating and moving parts as they will cause injury if contacted.
- Ensure that the engine operation switch is in the OFF position and the spark plug lead is disconnected before performing maintenance or making adjustments.
- Ensure both the machine and the operator are stable so the machine will not tip over, slide, or fall on un-even terrain while in operation or unattended.

- Do not leave the machine running while unattended.
- Ensure that the area to be dug does not contain any live electrical cables, gas, water, sprinkler, communication cables or any other utilities.
- Exercise care when operating unit. Exposure to vibration or repetitive work actions may be harmful to hands and arms.
- NEVER stand on the unit while it is operating. NEVER allow others to stand on the unit.
- Be careful not to come in contact with the muffler when the engine is hot. This will cause burns.
- Ensure that the repairs to the motor and machine are carried out by qualified personnel.



**Know what's below.
Call before you dig.**



1.4. Fire and Explosion Hazards

- Gasoline is extremely flammable and explosive under certain conditions.
- Ensure that gasoline is only stored in approved storage containers.
- DO NOT refuel the motor while it is running. Allow the motor to totally cool before refueling.
- DO NOT refuel the motor in the vicinity of sparks, flame or anyone smoking.
- DO NOT overfill the fuel tank and avoid spilling gasoline when refueling. Spilled gasoline or gasoline vapor may ignite. If spillage occurs, ensure that the area is cleaned and dry before starting the motor.
- Ensure that the fuel cap is securely fitted after refueling.



1.5. Chemical Hazards

- DO NOT operate or refuel a gasoline engine in a confined space or any area without adequate ventilation.
- Carbon monoxide and other components of exhaust gases from internal combustion engines can cause death in confined spaces.



1.6. Noise Hazards

- Excessive noise can lead to temporary or permanent loss of hearing.
- Wear an approved hearing protection device to limit noise exposure.



1.7. Protective clothing

- Always wear approved hearing and eye protection when working with the machine.
- Protective eyewear and a dust mask should be worn.
- Protective clothing and footwear are required.
- Do not wear any open-toed shoes or sandals.



1.8. Operator Safety using Internal Combustion Engines

- DO NOT smoke when refueling the engine or during any other fuel handling operation.
- DO NOT refuel a hot or running engine.
- DO NOT refuel the engine near an open flame or sparks.

- DO NOT spill fuel when refueling the engine.
- If fuel is spilled during refueling, wipe it off from the engine immediately and discard the rag in a safe place.
- DO NOT operate the unit if fuel or oil leaks exist. Repair immediately.
- Never operate this equipment in an explosive atmosphere or anywhere combustible gases have accumulated.
- Never operate any gas-powered equipment in a poorly ventilated or enclosed area.
- Avoid prolonged breathing of exhaust gases.
- Avoid contact with hot exhaust systems and engine parts.
- Allow engine to cool before performing any repairs, adjustments, or service.
- Always transport and handle fuel only in approved safety containers.
- Always keep the area around the muffler free of debris, such as leaves, paper cartons or anything combustible. A hot muffler could ignite debris and start a fire.

2. Un-Crating and Assembly

Remove the sides and top of the crate.

Using a suitable jack or lifting device, tip the unit up, and install the Wheels, one at a time, using the four lug nuts per side.

Torque the lug nuts to 85 Ft.-Lb.

2.1. Towbar Adjustment

Slide the Towbar pins outward and insert the Towbar into the tank brackets. Lock the two pins in place.

Remove the pin from the forward Towbar bracket.

Pivot the unit down until the holes align and insert the pin.

If the pin holes do not line up satisfactorily, loosen the three 7/16" nuts holding the forward bracket on the towbar.

Slide the bracket along the Towbar until the pin holes align.

Re-tighten the three 7/16" nuts to 35 Ft.-Lb. while the pin is in place.

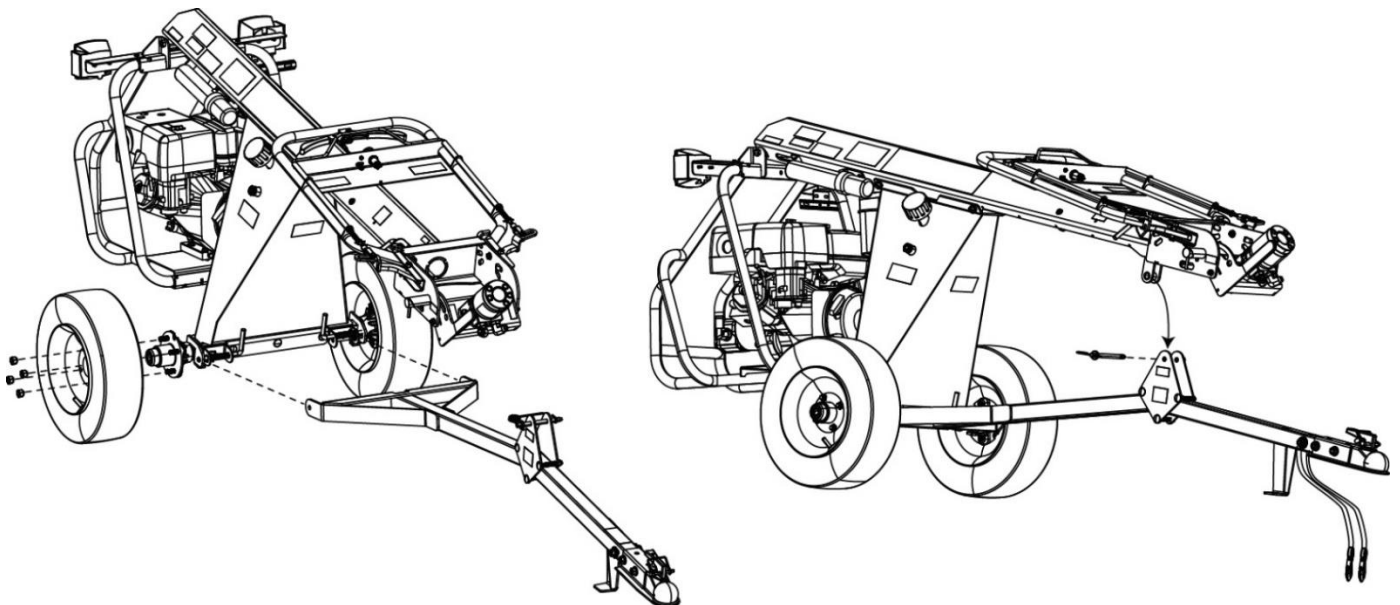



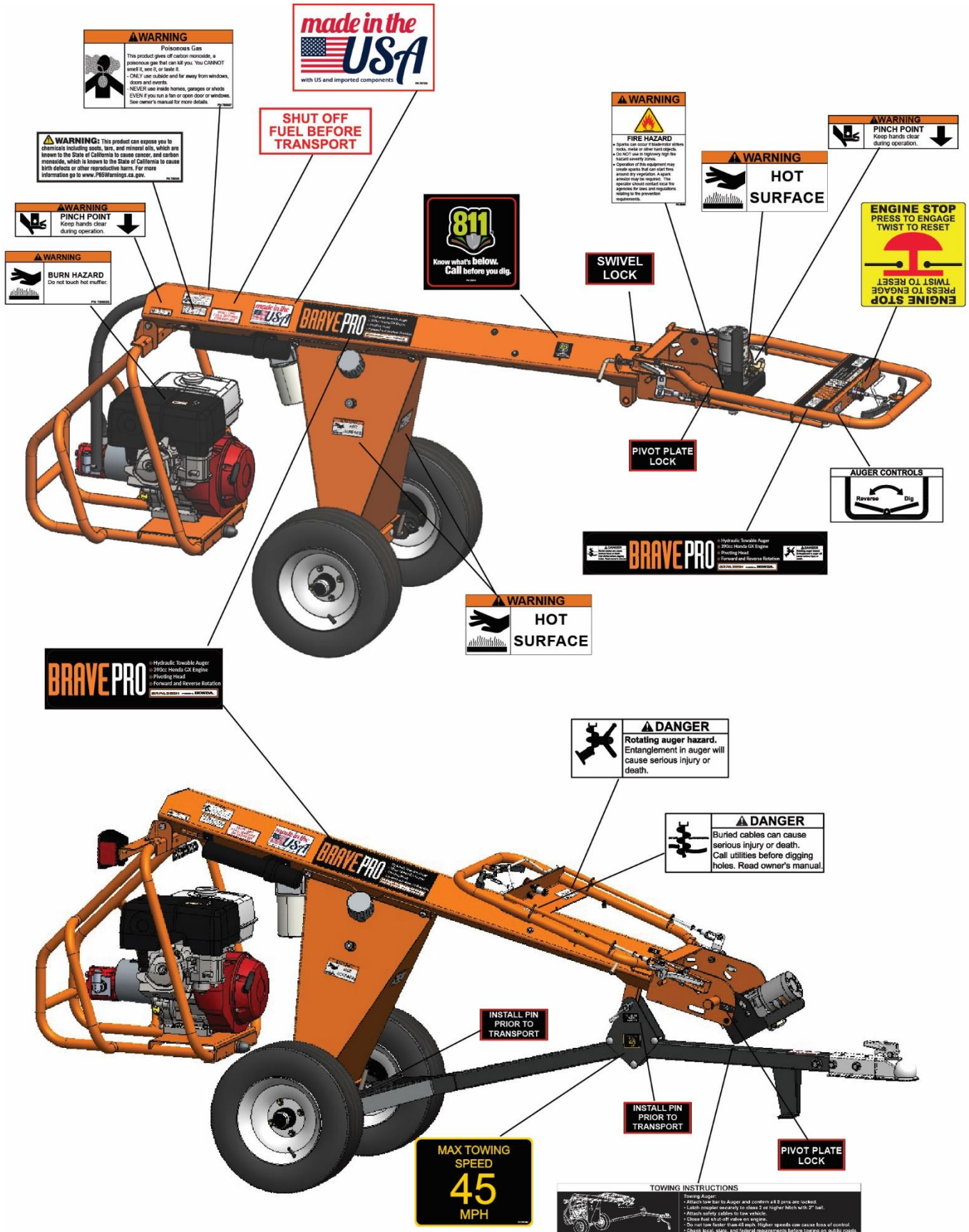





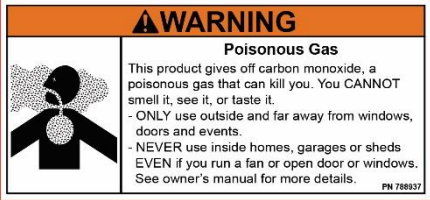



3. Label Locations















3.1. Safety and Operating Labels



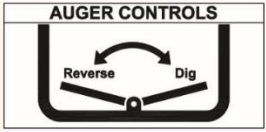
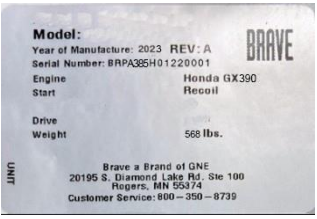

Brave Pro Machines use international pictorial labels where needed. These labels are described below:

Label	Meaning
 <p>WARNING Poisonous Gas This product gives off carbon monoxide, a poisonous gas that can kill you. You CANNOT smell it, see it, or taste it. - ONLY use outside and far away from windows, doors and vents. - NEVER use inside homes, garages or sheds EVEN if you run a fan or open door or windows. See owner's manual for more details. PN 788937</p>	<p>DANGER </p> <p>Engines emit carbon monoxide; operate only in well-ventilated areas. Read the Operation Manual for machine information. No sparks, flames, or burning objects near the machine. Shut off the engine before refueling. Use only clean, filtered unleaded gasoline.</p>
 <p>DANGER Buried cables can cause serious injury or death. Call utilities before digging holes. Read owner's manual.</p>	<p>DANGER </p> <p>Buried Utilities Danger</p>
 <p>DANGER Rotating auger hazard. Entanglement in auger will cause serious injury or death.</p>	<p>DANGER </p> <p>Keep hands, Feet and clothing clear of rotating blades.</p>
 <p>WARNING FIRE HAZARD • Sparks can occur if blades/rotor strikes rocks, metal or other hard objects. • Do NOT use in high/very high fire hazard severity zones. • Operation of the equipment may create sparks that can start fires around dry vegetation. A spark arrester may be required. The operator should contact local fire agencies for laws and regulations relating to fire prevention requirements. PN 788937</p>	<p>WARNING </p> <p>Fire Hazard. Do not use in high fire danger or dry conditions.</p>
 <p>811 Know what's below. Call before you dig. PN 788937</p>	<p>DANGER </p> <p>Never dig near buried gas, electrical or any other utility line. Call and have all utilities marked before digging.</p>
 <p>WARNING BURN HAZARD Do not touch hot muffler. PN 788635</p>	<p>WARNING </p> <p>Hot Surface. Mufflers, engines and Hydraulics can become very hot and cause burns.</p>

3.1. Safety and Operating Labels (cont.)

Label	Meaning
	<p>DANGER </p> <p>Emergency STOP.</p>
	<p>DANGER </p> <p>Towing Speed Limit 45MPH.</p>
	<p>CAUTION </p> <p>Always shut off fuel prior to towing.</p>
	<p>WARNING </p> <p>Pinch Point</p>
	<p>Auger Control</p>
	<p>Serial tag listing the model number and serial number. Please record the information found on this tag so it will be available if the tag is lost or damaged. When requesting service information, the serial number should be specified of the unit.</p>
	<p>WARNING </p> <p>Exposure hazard.</p>
	<p>WARNING </p> <p>Hydraulics components and engine may be HOT</p>

3.1. Safety and Operating Labels (cont.)

	<p>Lock the pivot for drilling on flat ground.</p>
	<p>DANGER  Tow Tongue MUST be properly secured before transporting.</p>
	<p>Lock motor pivot to move auger to drilling location.</p>
	<p>Tow Instructions</p>

4. Technical Data

4.1. Specifications.

Model	BRPA385H
Engine	Honda GX390
Power HP	13
Operating Weight (lb)	500 Lbs.
Bit Drive	7/8" Square standard – 1 3/8" Hex Optional
Hydraulic Reservoir	8 Gallon 10wt AW32
Digging Depth	42" std – extension available

4.2. Dimensions.

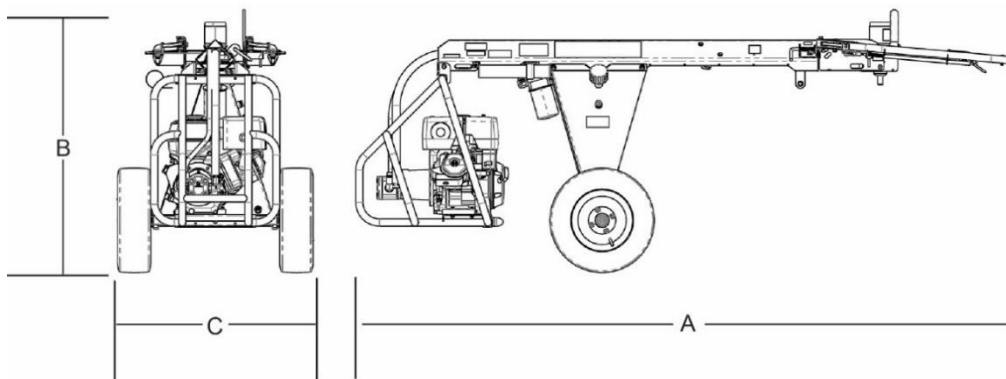

A	B	C
115 in.	45 ½ in.	34 in.

5. Operation

5.1. Operating Principle

The following instructions were compiled to provide you with information on how to obtain long and trouble-free use of this unit. Periodic maintenance of this unit is essential. Read the manual in its entirety and follow the instructions carefully. Failure to do so may injure yourself or a bystander.

5.2. Delivery Checks

On taking delivery of your new equipment and before putting it into service:

- Read the Operator's Manual completely – it could save a lot of time and unnecessary expense.
- Read the Engine Manual supplied.
- Check the general condition of the equipment – has it been damaged in shipment?
- Fill the engine with oil. **The engine is shipped without oil.** See Engine Manual for oil capacity and specification.
- Check the fuel level.
- Check the hydraulic oil level. Unit is shipped with hydraulic oil. Use 10wt AW32 Tractor Hydraulic Oil. *DO NOT mix tractor hydraulic oil with transmission fluid. Do NOT mix synthetic and non-synthetic hydraulic oils.*

5.3. Before Starting

The following Pre-start inspection must be performed before the start of each work session or after four hours of use, whichever is first. If any fault is discovered, the Auger must not be used until the fault is rectified.

1. Thoroughly inspect the Auger for signs of damage. Check components are present and secure.
2. Check the engine oil level. **The engine is delivered without oil installed.**
3. Check the engine fuel level and top up as necessary.
4. Check for fuel or oil leaks.

NOTICE. Check the oil level. Engine and Auger warranties are VOID if the unit is run without oil.

5.4. Gasoline Engine

1. Open the fuel tap by moving the fuel ON/OFF lever fully to the right.
2. If starting the engine from cold, set the choke ON by moving the choke lever fully to the left. When restarting a warm engine, the choke is usually not required. However, if the engine has cooled to a degree, partial choke may be required.
3. Turn the engine ON/OFF switch clockwise to the "I" position.
4. Ensure the E-stop switch on the operator's panel is out.
5. Set the throttle to approximately $\frac{1}{4}$ from the idle position by moving the throttle lever.
6. Do not start the engine at full throttle.
7. Taking a firm hold of the control handle with one hand, grasp the recoil starter handle with the other. Pull the recoil starter until engine resistance is felt, then let the starter rope return.
8. Taking care not to pull the starter's rope fully out, pull the starter handle briskly.

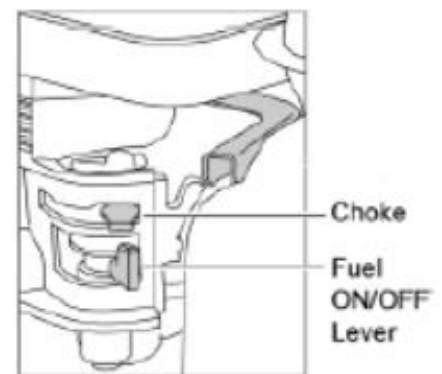

9. Repeat until the engine starts.
10. Once the engine starts, gradually set the choke lever to the OFF position by moving it to the right.
11. To stop the engine, set the throttle to idle and turn the engine ON /OFF switch counterclockwise to the "0" position.
12. Turn the fuel off.

5.5. Adjustments

BravePro equipment is made to the highest standards and is fully adjusted at the factory. However things can go out of adjustment during shipping or over time and with use.

Auger Drive Control: Check that the Auger Drive Control is getting full travel in both the forward and reverse

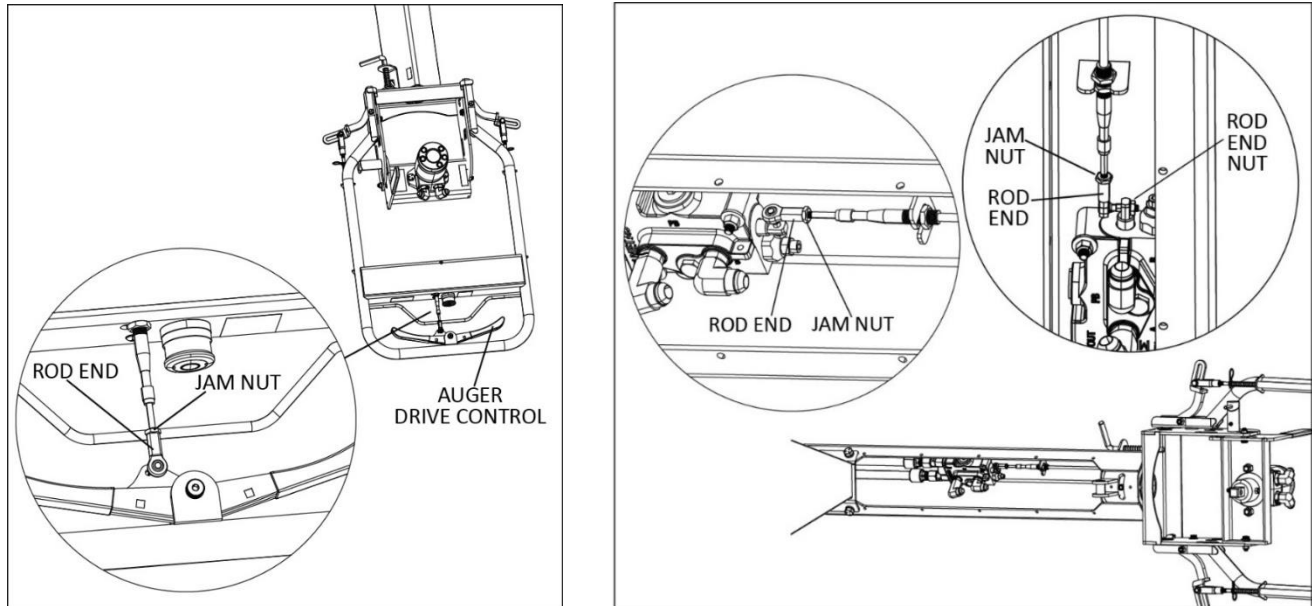

directions. The Auger Drive control should just touch the handlebar at the fully open position. If the cable comes tight before the control touches the handlebar in either direction, the cable should be adjusted. Loosen the jam nut near the cable rod end. Remove the rod end nut and slide the rod end out of the auger drive control. Turn the rod end further onto the cable shaft to shorten the throw, or thread the rod end outward on the cable shaft to lengthen the throw. Replace the rod end into the auger control and secure with the rod end nut. Re-tighten the jam nut against the rod end. The cable may be adjusted at either the auger control end or the valve end if more adjustment is needed.

Handle Release: Check that the handle release operates freely without binding.

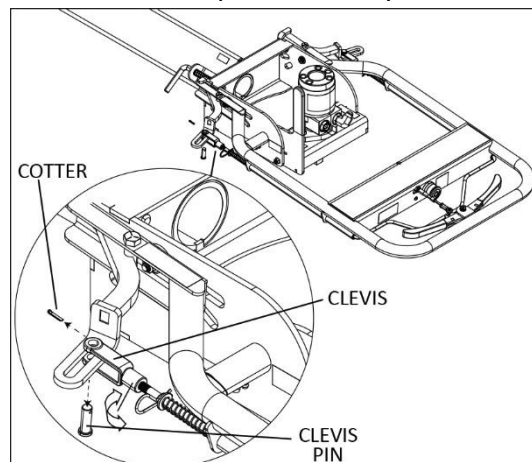

If adjustment is required, the clevis pin must be removed from the clevis yoke on each side. The clevis yoke may then be threaded more, or less onto the handle release rod. Keep the balance between each side so the latches release at the same time.

Replace the clevis pin and cotter pin.

5.6. Attaching The Auger Bit

The auger is supplied with a 7/8" square bit adapter. To use 1-3/8" Hex Drive bits, the optional GPR111484 Bit adapter must be used.

Align auger bit to motor adapter and secure with 5/16 x 2" clevis pin and hairpin cotter.

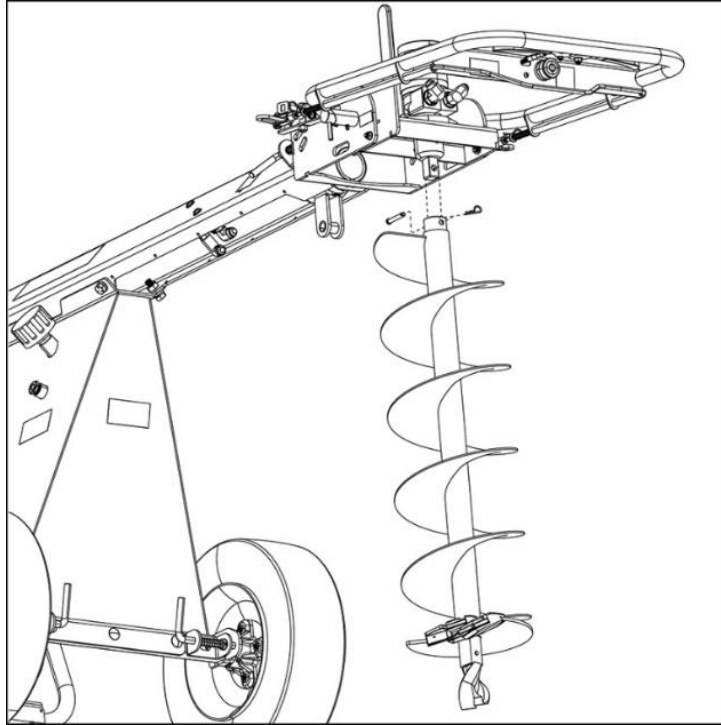

5.7. Auger Control

To start the bit rotating, pull the right-hand side of the Drive Handle toward the handlebar. To reverse rotation, pull the left-hand side of the drive handle toward the handlebar.

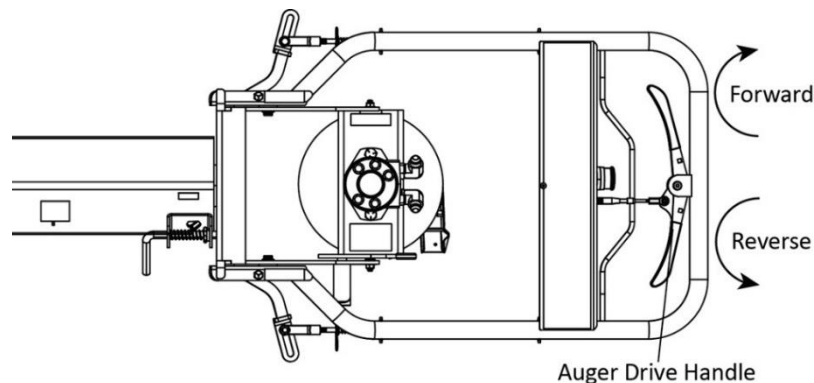

5.8. Handle Position

When drilling holes near a wall or other obstruction, the handle may be folded back to get closer to the obstruction.

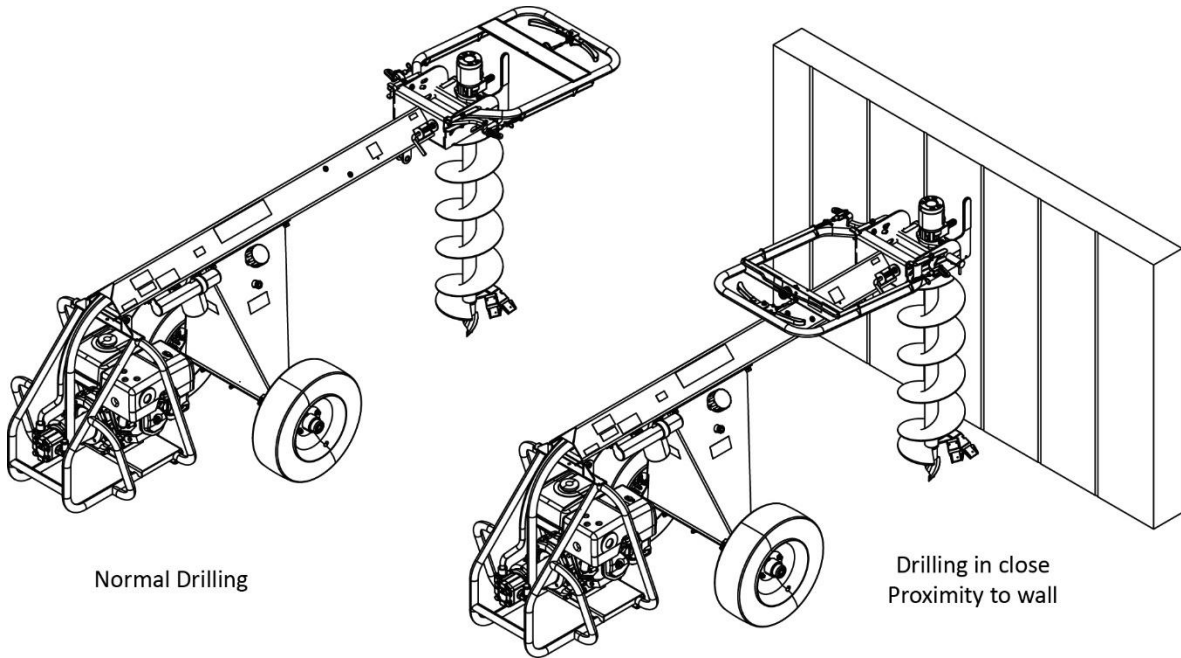

Pull the Handle Fold Release, and shift the handle back, clearing the way to drill closer to the obstruction.

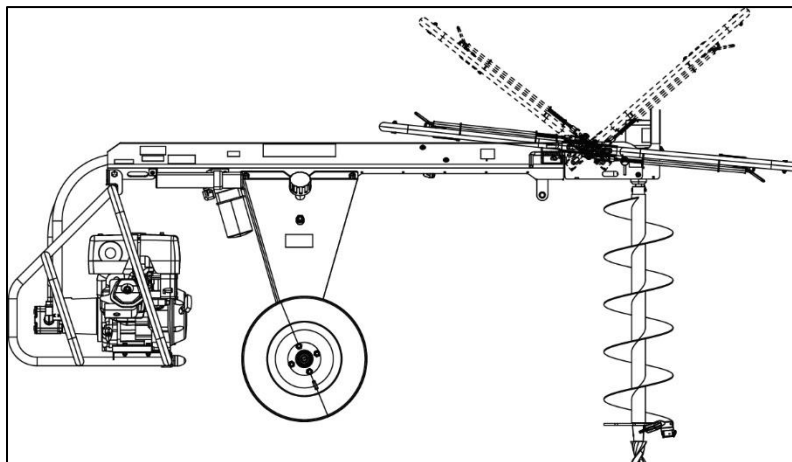
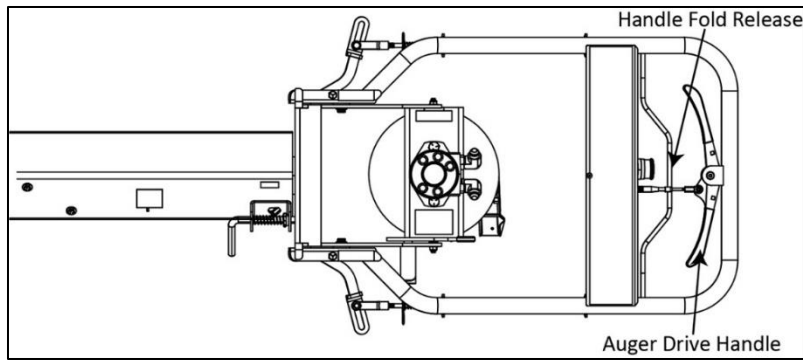

5.9. Swivel Lock

When drilling on un-even terrain, the head may be unlocked and allowed to swivel to allow perpendicular holes on sloped ground. Pull the swivel lock pin back and swivel the head.



Always drill across a slope and never uphill.

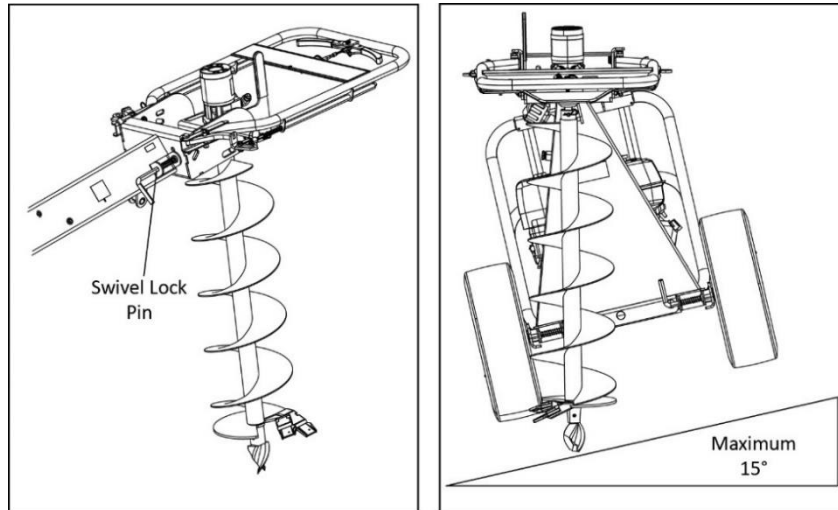

5.10. Digging

Always keep hands and feet clear of the auger and rotating parts.

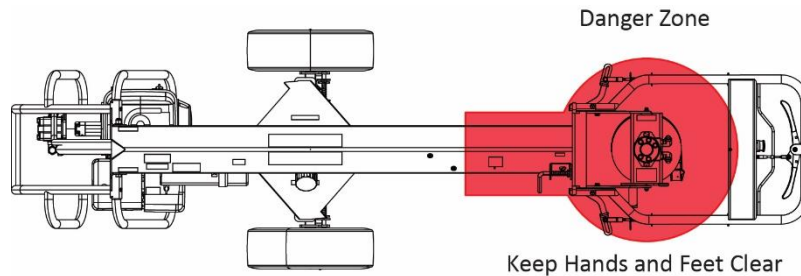

Raise the auger bit above the ground, squeeze the auger drive control to the right side of the handlebar and the bit will start rotating clockwise, viewed from the top. Maintain a firm grip on the auger and lower the bit until it touches the ground. Apply downward pressure and allow the unit to dig. Keep the angle of the bit straight up and down during digging.

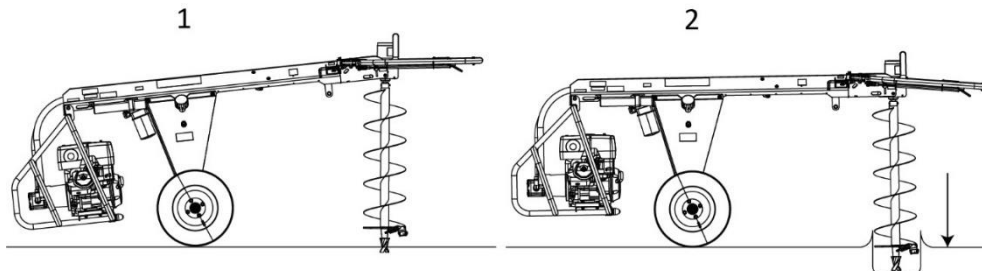

Continue digging until about a foot deep. Lift the unit, with the bit still rotating, to clear dirt from the hole.

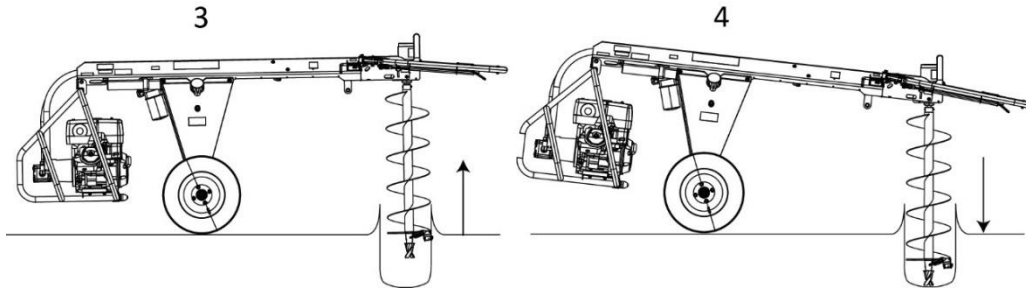

Repeat the digging motion, periodically raising the bit to clear dirt from the hole until it reaches the desired depth.

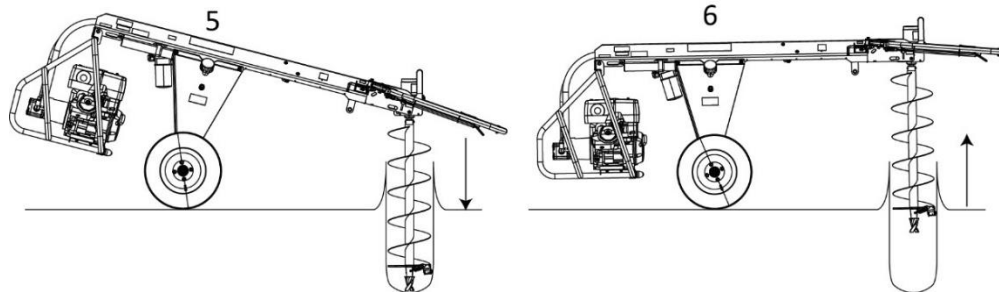

The Handle may be adjusted during digging. As the hole gets deeper, adjust the handle up, for a more comfortable position.

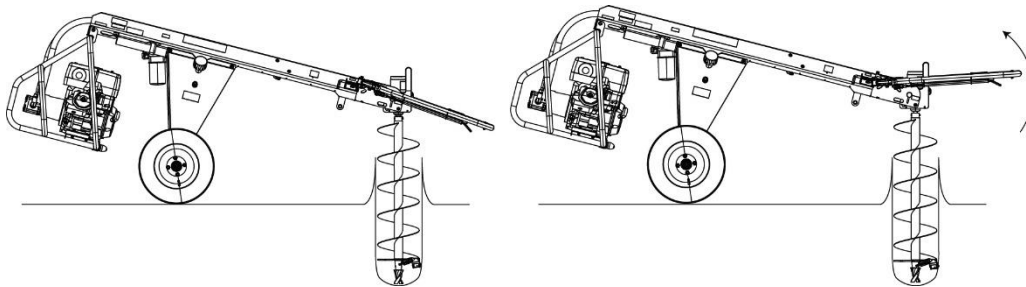

If digging deeper than the length of the bit, obtain a bit extension. Using the extension, you must first dig the hole approximately 18" deep without the extension, stop the machine and shut off the engine. Detach the bit from the auger and install the extension. Re-start the auger and continue digging to desired depth. Raise the bit, shut off the auger engine, and remove the extension.

If the bit starts to become stuck on a root, rock, or dense clay, reverse the rotation of the bit by squeezing the drive control to the left. Clear the obstacle and resume digging slowly. Use care to keep the angle of the bit straight up and down during digging.

5.11. Moving Between Holes

The bit may be angled back and temporarily latched to facilitate moving the unit between hole locations. Swivel the latch pin to disengage, angle the bit back and re-engage the pin. Move to the next location and release the latch.

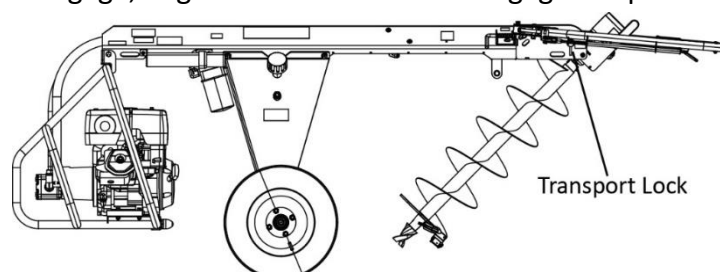

6. Parts

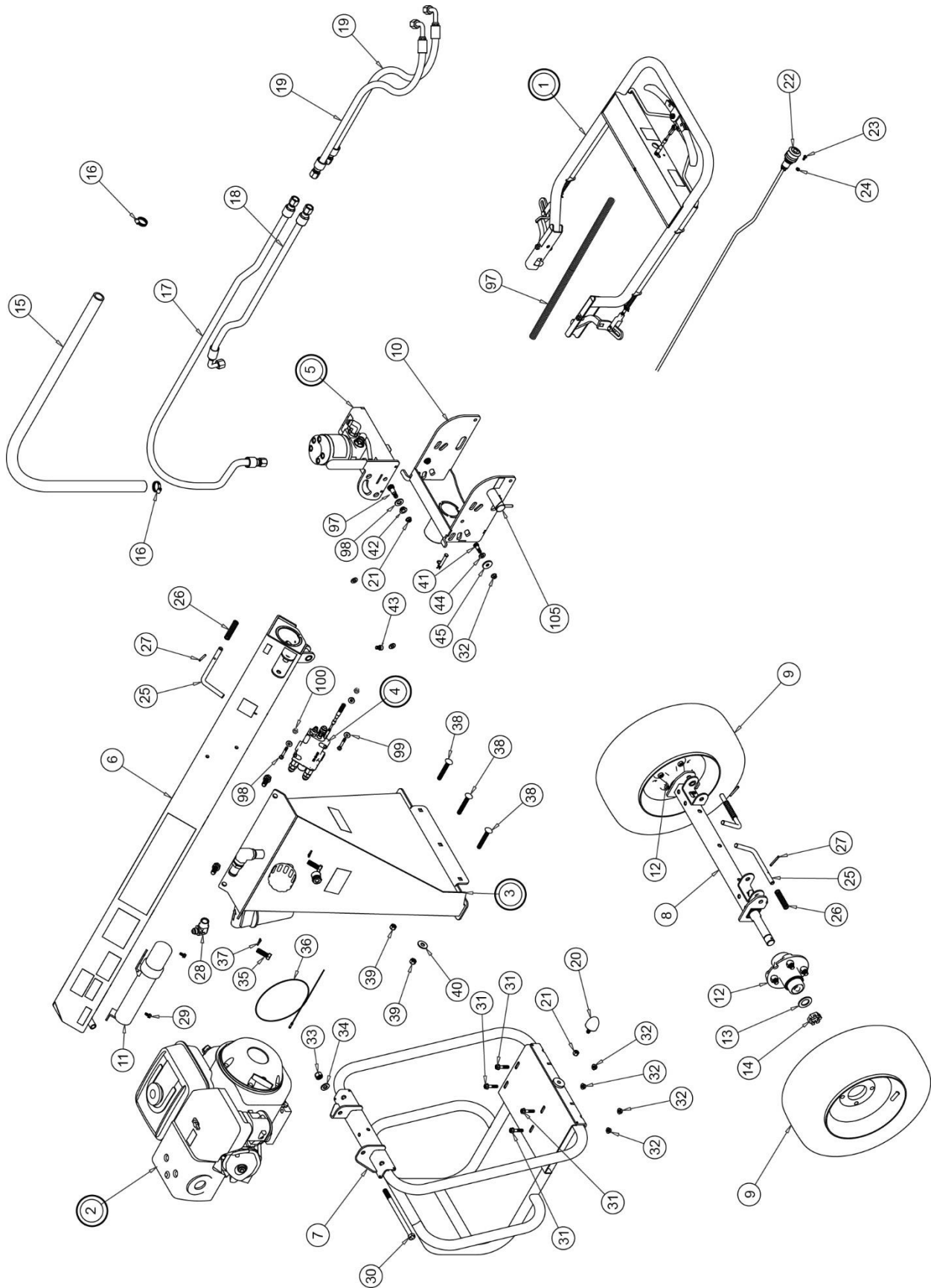



6.1. Master Parts List

Key #	Part No.	Description	Qty	Key #	Part No.	Description	Qty
1	See Inset	Handle Assembly (See Inset)	1	58	GPR111458	Cable, Auger Drive	1
2	See Inset	Engine/Pump Assembly (See Inset)	1	59		Honda Engine GX390	1
3	See Inset	Tank Assembly (See Inset)	1	60	GPR111459	Pump Mount	1
4	See Inset	Valve assembly (See Inset)	1	61	GPR111460	Coupler 1" Bore	1
5	See Inset	Motorhead Assembly (See Inset)	1	62	GPR111461	Coupler Spider	1
6	GPR111406	Main Beam	1	63	GPR111462	Coupler 5/8" Bore	1
7	GPR111407	Engine Cradle	1	64	GPR111463	Hydraulic Pump	1
8	GPR111408	Axle Assembly	1	65	GPR111464	Elbow Fitting 6801-08-10	2
9	GPR111409	Wheel-Tire 5.70/5.00-8	2	66	GPR111465	Elbow Fitting 4601-16-12	1
10	GPR111410	Yoke, Motor Mount	1	67	GPR111466	Tank Weldment	1
11	GPR111411	Manual Holder	1	68	GPR111467	Hydraulic Oil Cap - vented	1
12	GPR111412	Wheel Hub w/bearings	2	69	GPR111468	Filter Head 4"	1
13	GPR111413	Axle Washer	2	70	GPR111469	Filter Cartridge	1
14	GPR111414	Axle Nut, Slotted	2	71	GPR111470	Sight Glass - Hydraulic oil	1
15	GPR111415	Hydraulic Hose, Suction 1" x 60"	1	72	GPR111471	Drain Plug - Magnetic 1/2" NPT	1
16	GPR111416	Hose Clamp, 1"	2	73	GPR111472	Straight Fitting 4404-16-12	1
17	GPR111417	Hydraulic Hose, Pump to Valve 84"	1	74	GPR111473	Elbow Fitting 5504-12-12	1
18	GPR111418	Hydraulic Hose, Pump to Valve 48"	1	75	GPR111474	Valve, Hydraulic	1
19	GPR111419	Hydraulic Hose, Valve to Pump 36"	2	76	GPR111475	Fitting, Extender 6410-06-06	2
20	GPR111420	Bumper, Engine Cradle	1	77	GPR111476	Fitting Adapter 6400-08-06	2
21	GPR111421	Nylon Flange Locknut, 3/8-16	6	78	GPR111477	Fitting Elbow 6801-II-08-06	1
22	GPR111422	Engine Stop Switch w/harness	1	79	GPR111478	Fitting Elbow 6801-08-06	1
23	GPR111423	Pan Head Phillips Screw 10-32 x 1/2"	1	80	GPR111479	Hydraulic Motor	1
24	GPR111424	KEPS Nut 10-32	3	81	GPR111480	Grip, Motor Pivot Handle	1
25	GPR111425	L-Rod, Spring Latch	3	82	GPR111481	Motorhead Weldment	1
26	GPR111426	Latch Spring	3	83	GPR111482	Bit Adapter 7/8" Square Drive	1
27	GPR111427	Roll Pin, Spring Latch	3	83	GPR111483	Bit Adapter 1-3/8" HEX Drive - Optional	1
28	GPR111428	Elbow, 3/4-16 JIC X 3/4 NPT	1	84	GPR111484	Hex Head Bolt 3/8-13 X 3"	1
29	GPR111429	Flange machine screw 1/4-20 x 1/2"	2	85	GPR111485	Tow Bar	1
30	GPR111430	Hex Head Bolt 1/2-13 x 8"	1	86	GPR111486	Side Plate Tow Bar	2
31	GPR111431	Flange Bolt 5/16-18 x 1-1/2"	4	87	GPR111487	Hitch Coupler - Tow Bar	1
32	GPR111432	Nylon Flange Lock Nut 5/16-18	6	88	GPR111488	Hitch Pin - 5/16	1
33	GPR111433	Nylon Locknut 1/2-13	6	89	GPR111489	Safety Cable - Tow Bar	1
34	GPR111434	Hex Head Bolt 1/2-13 x 1-1/2"	6	90	GPR111490	Flange Bolt 1/2-13 x 3"	2
34	GPR111435	Flatwasher SAE 1/2"	1	91	GPR111491	Flange Bolt 1/2-13 x 3-1/2"	1
36	GPR111436	E-stop Wire extension	1	92	GPR111492	Flatwasher 1/2"	2
37	GPR111437	Lockwasher 1/2"	4	93	GPR111493	Hitch Pin - 1/2"	1
38	GPR111438	Carriage Bolt 7/16-14 x 3"	6	97	GPR111494	1/2" Corrugated Conduit	1
39	GPR111439	Nylon Locknut 7/16-14	6	98	GPR111495	Hex Head Bolt 1/4-20 x 2-1/4"	2
40	GPR111440	Flatwasher 7/16"	3	99	GPR111496	Flatwasher 1/4"	4
41	GPR111441	3/8" Shoulder Bolt 5/16-18 x 5/8"	2	100	GPR111497	Nylon Locknut, 1/4-20	2
42	GPR111442	Bronze Bushing, Flange 1/2"	2	101	GPR111498	Clevis Pin, 5/16 x 2	1
43	GPR111443	Socket Head Bolt 3/8-16 x 1/2"	1	102	GPR111499	Hairpin Cotter	1
44	GPR111444	Flatwasher SAE 3/8"	6	103	GPR111500	Bumper, 3/8 x 1/4"	1
45	GPR111445	Thrust Bearing 3/8"	2	104	GPR111501	Lanyard, 18"	2
46	GPR111446	Handle bar Weldment	1	105	GPR111502	Twist Lock Plunger Pin, Yoke	1
47	GPR111447	Latch Handle	1		82155.DOS	Cable Tie	5
48	GPR111448	Handle Latch - Left	1		82157.DOS	Cable Tie	1
49	GPR111449	Handle Latch - Right	1		GPR111505	TOWBAR ASSEMBLY	1
50	GPR111450	Latch Clevis W/pin 5/16-24	2		ZUBRPA385H	Decal Sheet	1
51	GPR111451	Spring, Handle return	2		ZABRPA385H	Serial Tag	1
52	GPR111452	Flatwasher SAE 5/16"	2		GWG311009	Tail Light Kit - Optional	1
53	GPR111453	Hex Head Bolt 3/8-13 X 2"	2	94		Light Kit Mount Bracket	1
54	GPR111454	Auger Drive Handle	1	95		Tail Lights and License plate bracket	1
55	GPR111455	Rod End, ball joint 10-32	2	96		Light Kit Wire Extension	1
56	GPR111456	Shoulder Bolt 5/16-18 x 1	1	97	GPR111527	1/2" Shoulder Bolt 3/8-16 x 7/8"	2
57	GPR111457	Cotter Pin 3/32 x 1"	2	98	GPR111528	Washer 1/2" x 1/8" Thick - Hardened	4

6.2. Handle Assembly

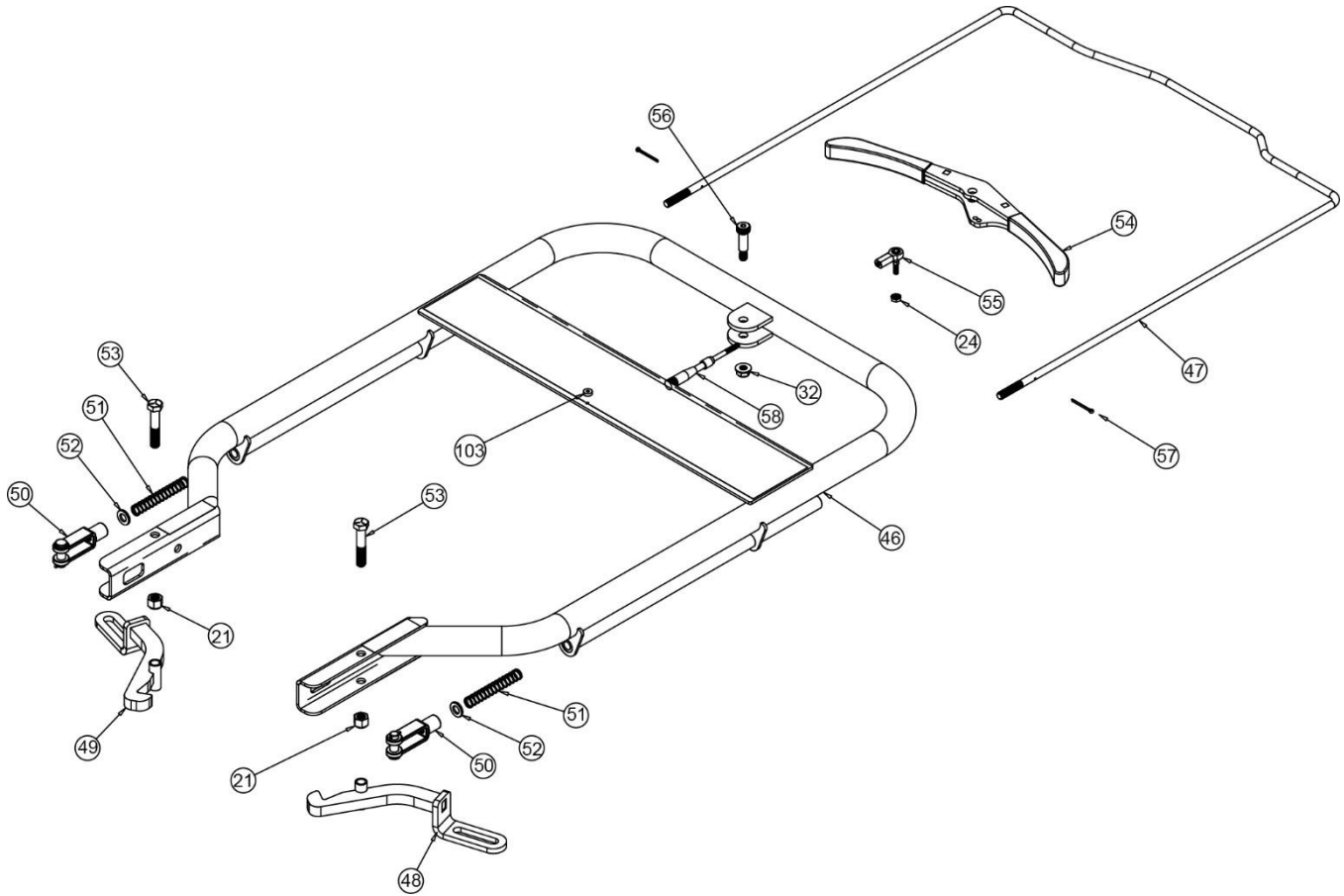

6.3. Engine – Pump Assembly

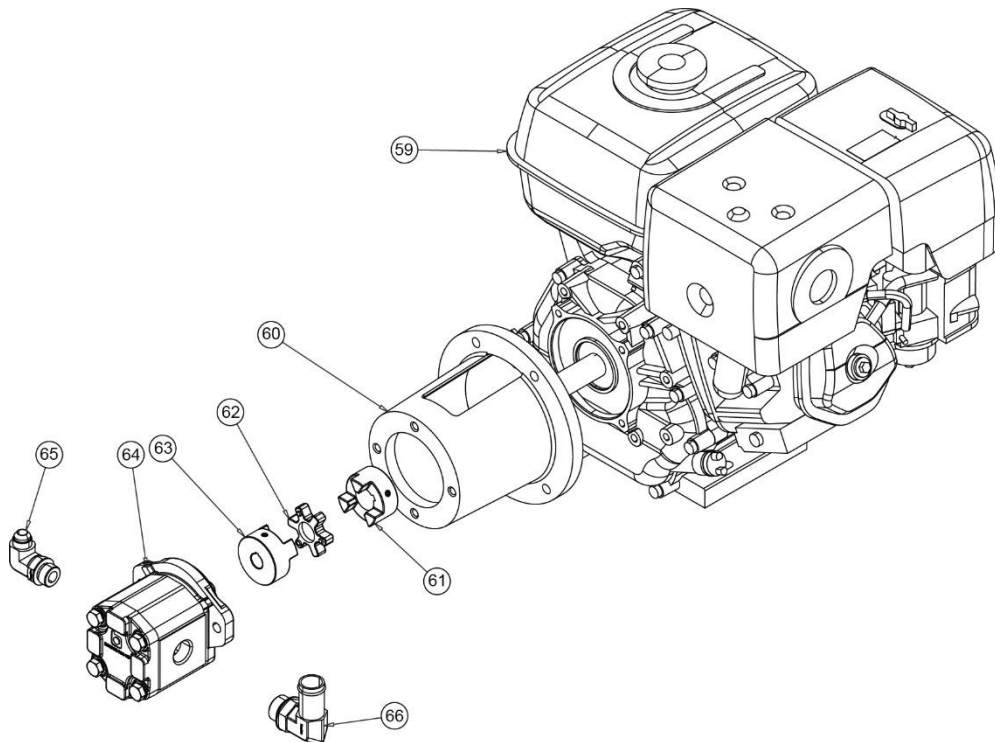

6.4. Tank Assembly

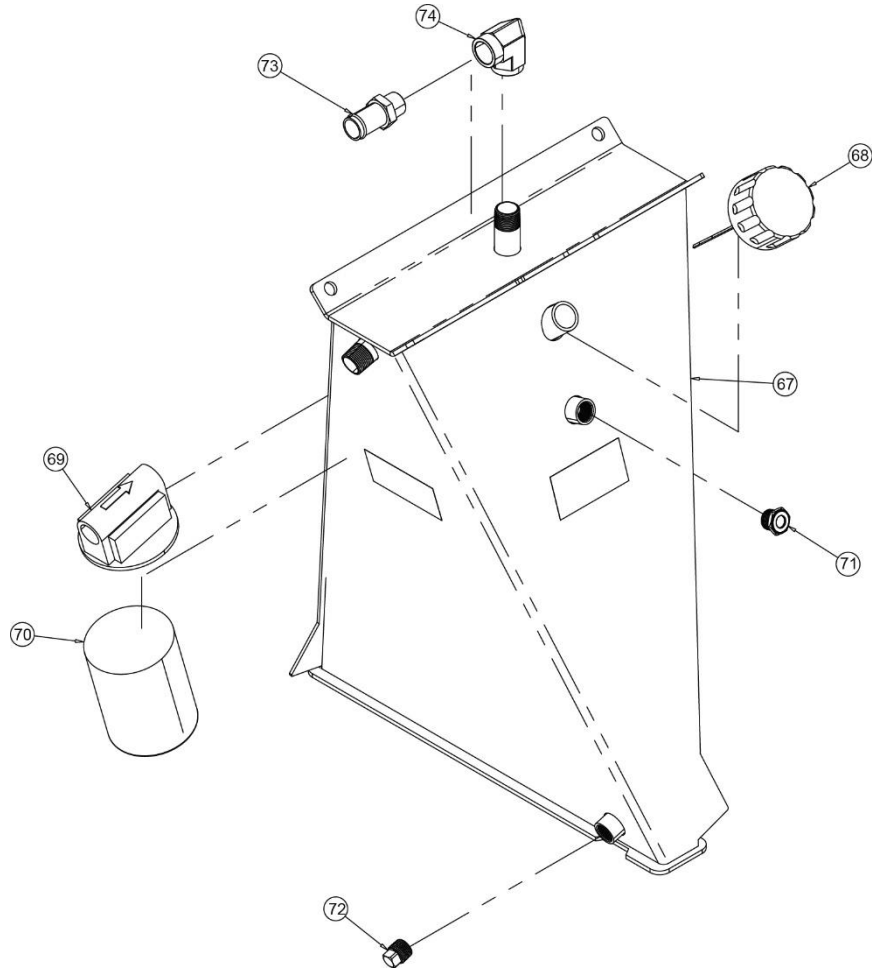

6.5. Valve Assembly

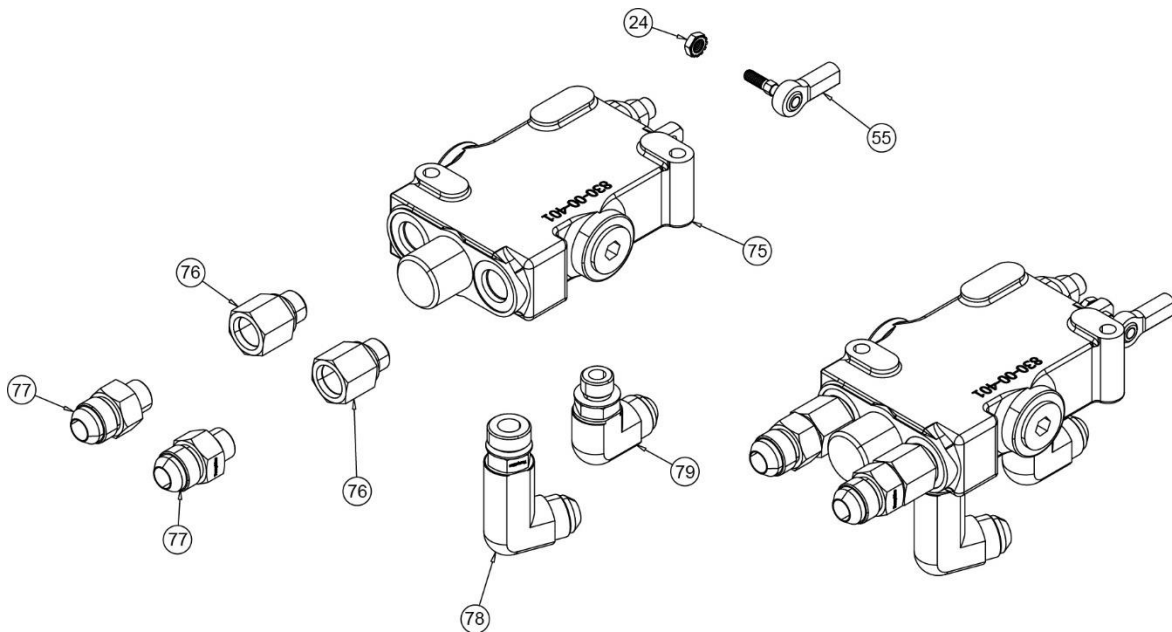

6.6. Motor Head Assembly

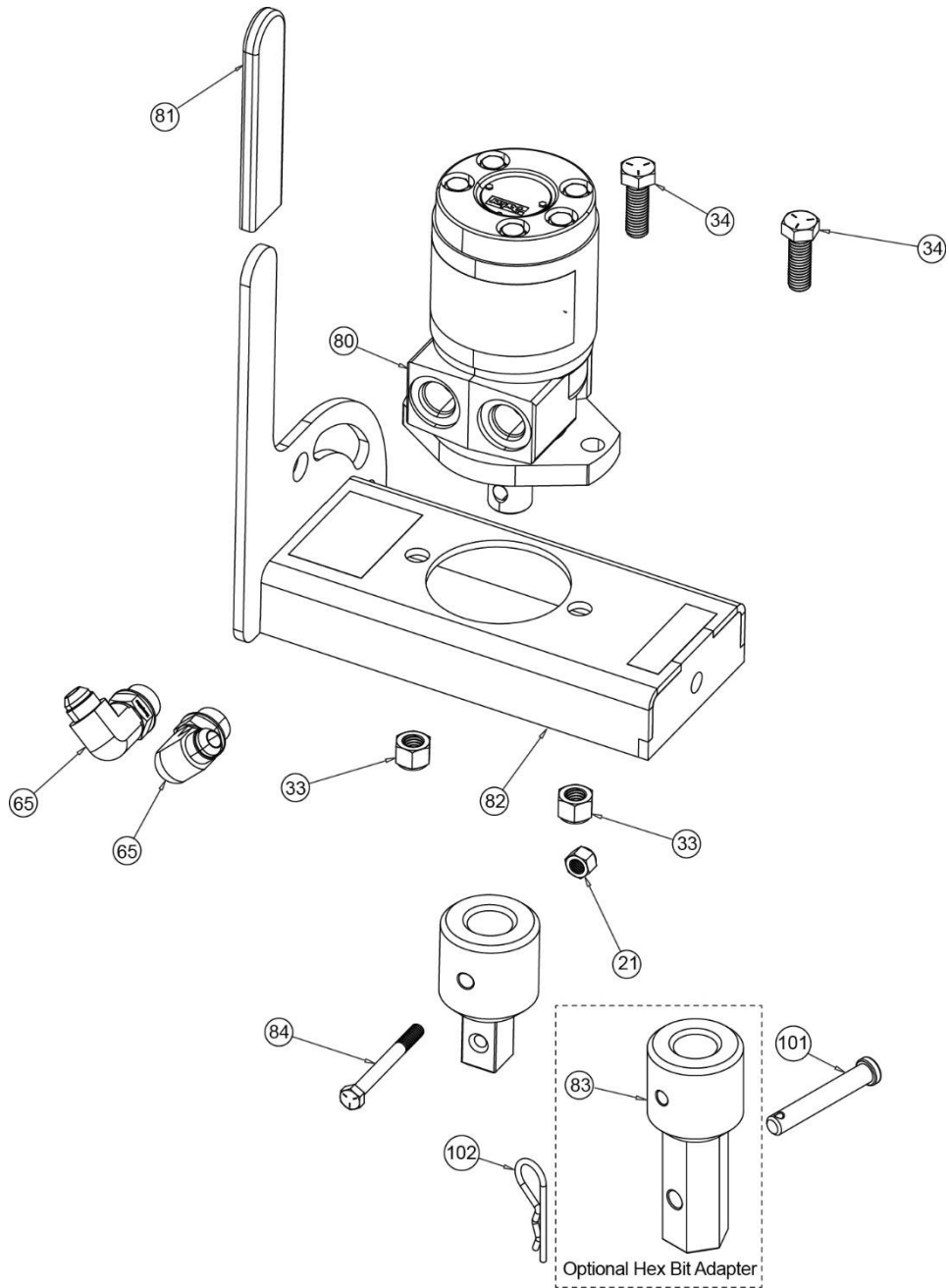

6.7. Towbar Assembly

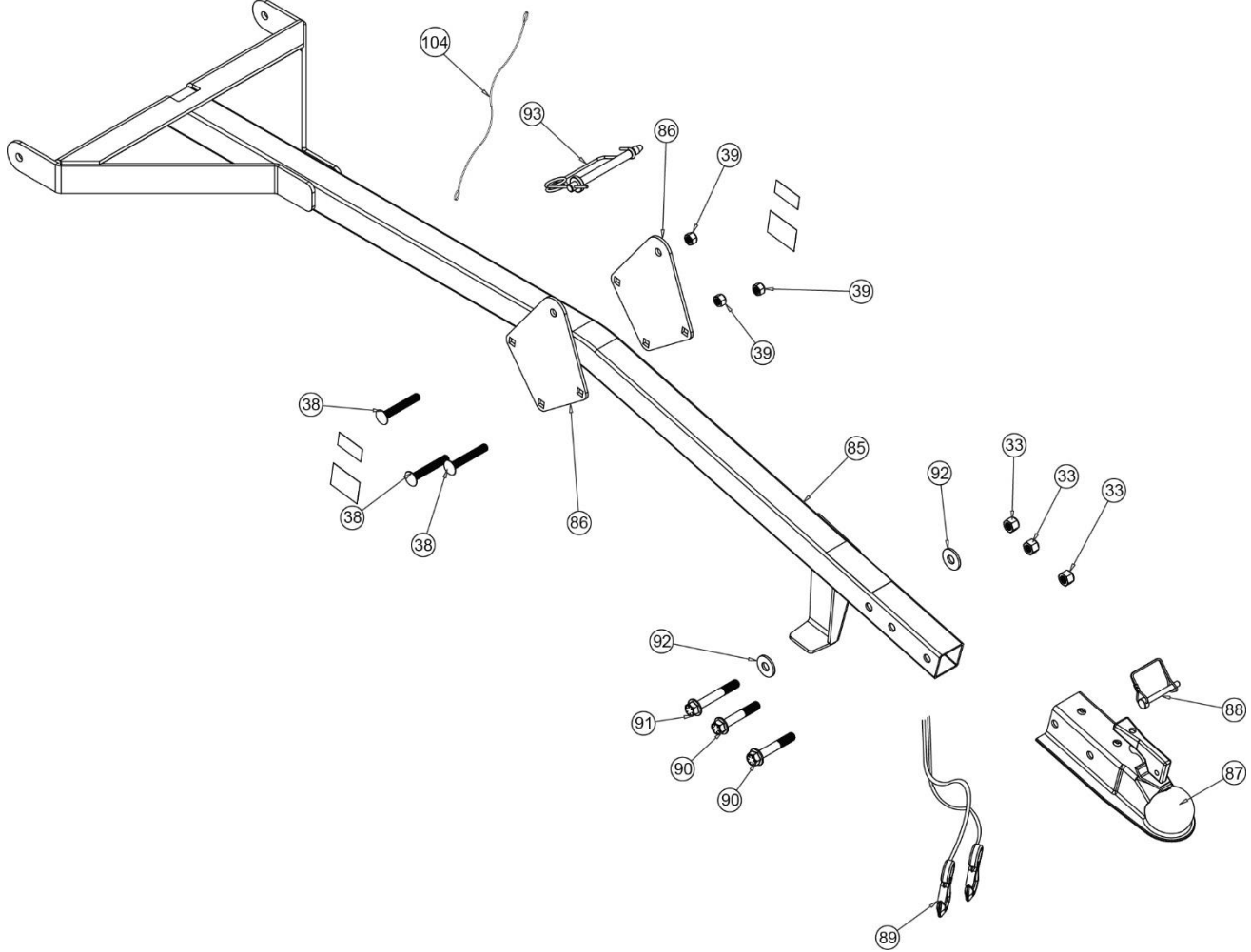

6.8. Optional Tail Light Kit Assembly - GWG311009

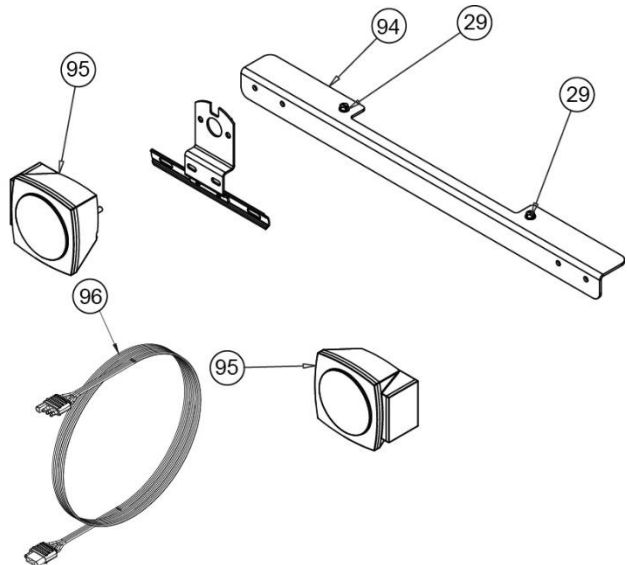
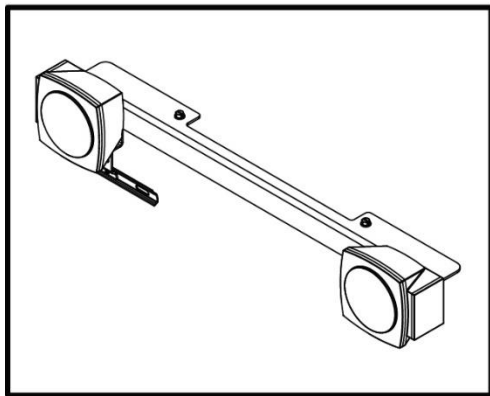

7. Maintenance

7.1. Periodic Maintenance Schedule.

Refer to the engine manufacturer's Operation Manual for additional information on engine maintenance. A copy of the engine Operation Manual was supplied with the machine when it shipped.

	Daily	At first 20 hours	Every 50 hours	Every 100 hours
(Starting check)	●			
Loose or lost screws	●			
Damage of any part	●			
E-stop Function	●			
Leakage of oil or fuel	●			
Tightness of fasteners	●			
Engine oil check and replenishment	●			
Engine oil replacement		●		●
Hydraulic Oil Check	●			
Hydraulic Oil and filter Replacement 10wt AW32				●
Air cleaner			●	
Handle Release Rod – Spray with dry lube	●			



These inspection intervals are for operation under normal conditions. Adjust your inspection intervals based on the working conditions. Dusty or wet environments may necessitate more frequent service.

7.2. Air Cleaner

1. The air filter element should be cleaned often because a clogged air cleaner can cause poor engine starting, lack of power and shorten the life of the engine substantially.
2. To clean or replace the air filter, loosen the wingnut on the air filter housing (Fig. 1), remove the cover and take out the air filter cartridge. If you are only cleaning the air filter, blow compressed air through the filter cartridge from the inside, moving to cover the entire filter area.

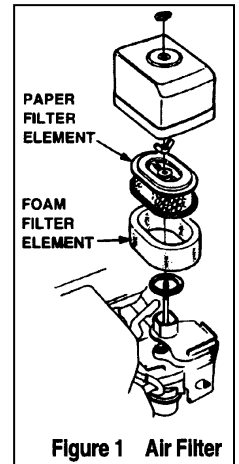

Figure 1 Air Filter

7.3. Spark Plug

Check and clean or replace spark plugs regularly.

A fouled, dirty spark plug may cause hard starting and poor engine performance. Set spark plug gap to recommended clearance. Refer to engine manual.



The muffler and engine cylinder become very hot during operation and remain hot for some time after stopping the engine. You could suffer burns. Allow engine to cool before removing spark plug.

NOTICE: a lose spark plug can become very hot and may cause engine damage.

8. Transporting

8.1. Prepare for towing.

1. Always shut off the engine when towing machine.
2. Secure the Auger tow bar and ensure pins are seated in 3 locations.
3. **Shut off the Fuel before towing.**

8.2. Attach Towbar

1. Rotate the Motor Head to the transport position and latch.
2. Attach towbar to tank bracket and secure the two spring pins.
3. Lower the unit and attach it with the hitch pin at the forward towbar bracket.
4. Secure the unit to an approved 2" ball hitch and close the ball coupler. Secure with pin.
5. Attach Safety Cables to the vehicle.
6. Connect trailer lights wire to vehicle if equipped.

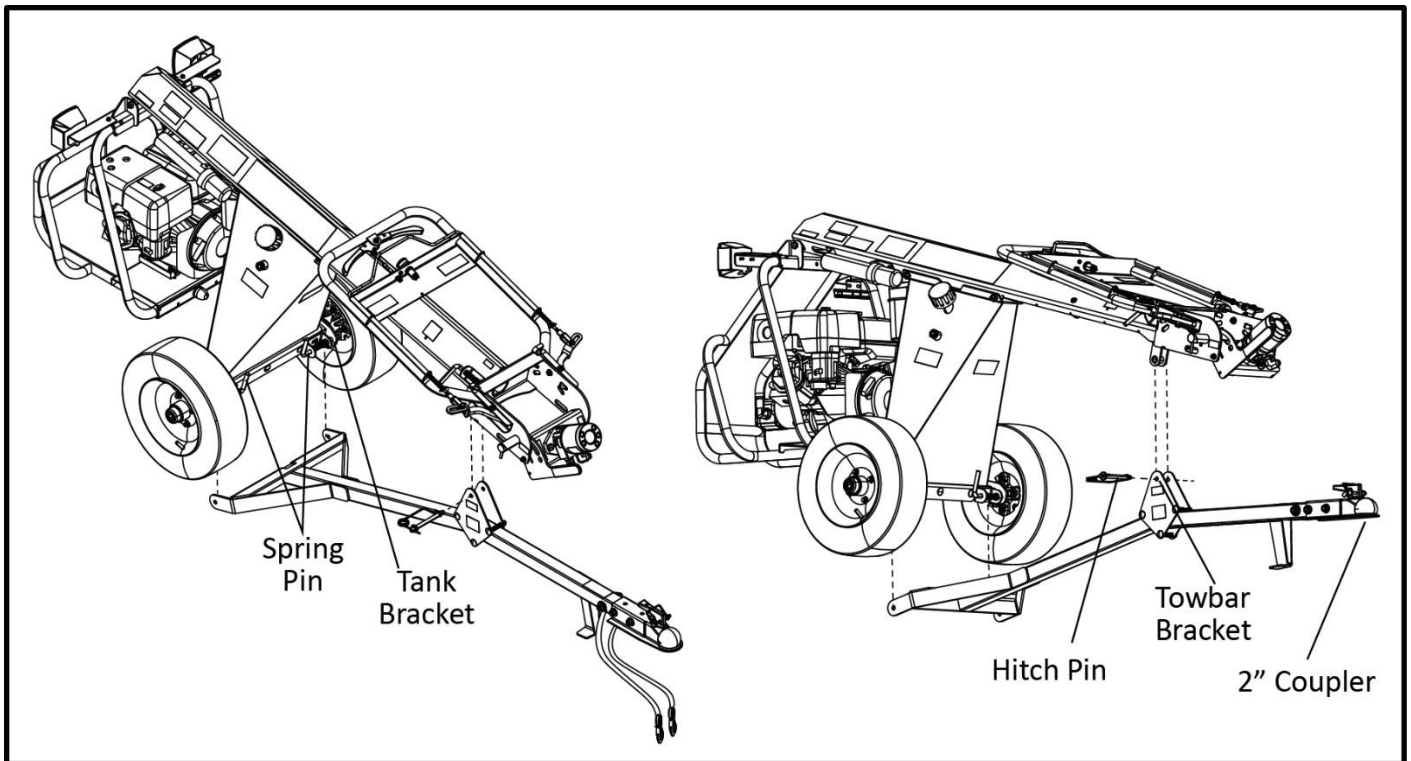

Maximum Tow Speed 45 MPH (70KPH)



20195 South Diamond Lake Road, Suite 100 • Rogers, MN 55374
Toll-Free: 800-350-8739 • Website: GNEDI.com • Email: Techservices@GNEDI.com



Dear Valued Customer:

The Brave product you just purchased is built with the finest material and craftsmanship. Use this product properly and enjoy the benefits from its high performance. By purchasing a Brave product, you show a desire for quality and durability. Like all mechanical equipment this unit requires a due amount of care. Treat this unit like the high-quality piece of machinery it is. Neglect and improper handling may impair its performance.

Thoroughly read the instructions and understand the operation before using your product. Always contact Brave Product Support at 1-800-350-8739 prior to having any service or warranty work performed, as some services performed by parties other than Brave approved service centers may void this warranty. This limited warranty is in lieu of any other warranty expressed or implied, written, or oral and Brave assumes no other responsibility or liability outside that expressed within this limited warranty.

**Limited Warranty for Brave Auger:
Model BRPA385H**

	Consumer Warranty Period	Commercial Warranty Period
Weldments	2 years from date of purchase by user	2 years from date of purchase by user
Wear Parts	In addition to the normal warranty, Brave shall warrant some normal wear items from defects in material or workmanship for a period of 30 days from the date of purchase by user. Normal wear items covered under this warranty are limited to: High impact wear related components such as standard retention hardware for wear items, chains, bits, sprockets, bearings, belts and bushings, centrifugal clutch components such as shoes, springs, drum and rotor assembly, rotors, rubber drapes or flaps, drive, and driven pulleys. Routine maintenance items such as lubricants, clutch adjustments, tune ups are not covered under warranty.	
Engines	The engine warranty is covered under the terms and conditions as outlined by the engine manufacturer’s warranty contained herein and is the sole responsibility of the engine manufacturer. Normal engine maintenance such as spark plugs, oil changes, air filters, adjustments, fuel system cleaning and obstruction due to build up is not covered by this Brave limited warranty.	

“Consumer use” means personal residential household use by a consumer. “Commercial use” means all other uses, including, but not limited to, use for commercial, income producing or rental purposes or when purchased by a business.

This limited warranty applies to the original purchaser of the equipment (verification of purchase, in the form of a receipt, is the responsibility of the buyer), is non-transferable, and covers parts and labor. Parts will be replaced or repaired at no charge, except when the equipment has failed due to lack of proper maintenance. If a part is no longer available, the part may be replaced with a similar part of equal function. Any misuse, abuse, alteration or improper installation or operations will void the warranty. Determining whether a part is to be replaced or repaired is the sole decision of Brave. Brave will not provide replacement of complete products due to defective parts. Any costs incurred due to replacement or repair of items outside of a Brave approved facility is the responsibility of the buyer and not covered under warranty. Transportation costs to and from the service center and/or service calls are the responsibility of the customer.

This limited warranty specifically excludes the following: failure of parts due to damage caused by accident, fire, flood, windstorm, acts of God, applications not approved by Brave in writing, corrosion caused by chemicals, use of replacement parts which do not conform to manufacturer’s specifications, damage related to rodent and/or insect infestation and damage caused by vandalism. Additional exclusions: loss of running time, inconvenience, loss of income, or loss of use, including any implied warranty of merchantability of fitness for a specific use. Also, outdoor power equipment needs periodic parts and service to perform well, and this limited warranty does not cover instances when normal use has exhausted the life of a component or the engine.

This limited warranty does not cover any personal injury or damage to surrounding property caused by failure of any part, misuse, or inability to use the product. Alteration of the product, including safety features, shall void this limited warranty.

Repair or replacement of parts does not extend the warranty period. This limited warranty gives you specific legal rights. You may also have other rights that vary by state. Please have model number, item number and serial number on hand prior to making a warranty claim or inquiry.