

BRAVE

OPERATOR'S MANUAL

Safety, Operation & Service Information

100 Series One-Man Auger

Model: BRPA180H

Form: GOM08042002US, Version 1.1, Original Instructions

- Do not discard this manual.
- Keep manual readily available for reference during operation or when servicing product.
- Before operation, read and comprehend operator manual content.
- When ordering replacement parts, please supply the following information: model number, serial number and part number.
- **Customer Service:** 1-800-359-8739
- **Customer Service Telefax:** 1-866-779-9963
Note: There is no charge for Customer Service.
- **Internet Address:** <http://www.braveproducts.com>
- **Email:** sales@braveproducts.com

Copyright 2020, Brave, All rights reserved.

TABLE OF CONTENTS

1 INTRODUCTION 3
 2 INTENDED USE 3
 3 TRAINING 3
 4 SAFETY SYMBOLS 3
 5 SAFETY INSTRUCTIONS 3
 6 MACHINE SPECIFICATIONS 6
 7 STANDARD PRODUCTS & ACCESSORIES 6
 8 MACHINE SET-UP 7
 9 APPLICATION THEORY & TECHNIQUES 8
 10 OPERATING INSTRUCTIONS 9
 11 MAINTENANCE INSTRUCTIONS 13
 12 SERVICE/REPAIR INSTRUCTIONS 16
 13 TROUBLESHOOTING 19
 14 STORAGE 19
 15 END OF LIFECYCLE 20
 16 WARRANTY 21
 17 PRODUCT REGISTRATION 22
 18 REPLACEMENT PARTS 24

- It is responsibility of owner(s) and/or operator(s) to determine no modifications and/or alterations have been made to Auger. Modifications and/or alterations can lead to possibility of serious damage, injury or even death. It is responsibility of owner(s) and/or operator(s) to make this Operator Manual available for consultation during all phases of operation.
- Refer to OSHA 2207 and/or applicable updated revisions which contains all OSHA job safety, health rules and regulations (1926 and 1910) covering construction.

CAUTION

The concept of portable, one and two man operated, hole digging equipment has been successfully utilized for over forty years as a practical solution to many types of hole digging job requirements. The basic concept is proven and well accepted within the associated marketplaces as an alternative method to manual labor and/or larger, mounted earth drilling machinery.

Use of an Auger requires strenuous work activity. This type of work activity can be considered to be greater in magnitude than that experienced with the use of many other types of both light construction and lawn and garden related equipment. This type of work activity should only be attempted by operators of adequate physical size and stature, mental awareness, and physical strength and condition.

Each operator is required to supply a resultant force that counteracts/balances and/or resists the natural torque and kickback forces generated during the hole digging process. The body parts most noticeably affected during the hole digging process are the arms, hands, wrists, shoulders, lower back and legs. The hole digging process can also produce excessive stress/strain directly to the back muscles, spinal vertebrae and many other body parts. Back related pain can be a side effect of the hole digging process. An operator with a chronic back related problem or a history of back and/or other medically related problems should not attempt to utilize the Auger. Use of the Auger may only aggravate this and any other medically related problem.

The torque and kickback forces generated and/or encountered correspond to natural laws of physics and are inherent to the hole digging process. They cannot be changed or totally eliminated with portable one and two man operated, hole digging equipment of this design. Proper operating positions and techniques, as outlined in this manual, can be successfully utilized to minimize the effects of the torque and kickback forces upon the human body.

Because of the diverse type of prevailing digging conditions, operator experience levels and operator physical characteristics, no warranty, guarantee, representation and/or liability is made by the manufacturer as to the absolute correctness or sufficiency of any operational procedure, operational position and/or technique. There is no absolute guarantee that an operator of any given experience level, physical size and/or physical condition will be immune to the possibility of and/or probable physical side effects of the normal hole digging process.

Each potential operator of the Auger must be made aware of and assume the operational and physical liability described and/or associated with the hole digging process when utilizing the Auger. **Each potential operator not willing to assume the operational and physical liability described and/or associated with the hole digging process should not operate the Auger.** Proper levels of operator experience, skill and common sense are essential for maximizing the safe and efficient operation of the Auger.

Record Auger and engine/electric motor serial numbers in spaces provided below.

Model Number: _____

Serial Number: _____

Engine/Electric Motor Serial Number: _____

Date of Purchase: _____

Specifications and design are subject to change without notice or obligation. All specifications are general in nature and are not intended for specific application purposes. General Equipment Company reserves the right to make changes in design, engineering or specifications and to add improvements or discontinue manufacture at any time without notice or obligation. General Equipment Company and its agents accept no responsibility for variations which may be evident in actual products, specifications, pictures and descriptions contained in this publication.

NOTICE TO OPERATORS

IF YOU CAN NOT READ OR DO NOT FULLY UNDERSTAND THE CONTENTS OF THIS MANUAL, PLEASE CONTACT THE FACTORY FOR PROPER ASSISTANCE BEFORE ATTEMPTING TO OPERATE THIS PRODUCT.

SI TU NO PUEDES LE'ER O NO COMPRENDES EL CONTENIDO DE ESTE MANUAL FAVOR DE PONERSE EN CONTACTO CON LA FABRICA PARA ASISTENCIA-APROPIA ANTES DE INTENTAR PARA OPERAR ESTE PRODUCTO.

SOLLTEN SIE DIESE GEBRAUCHSANWEISUNG NICHT LESEN KOENNEN ODER ES NICHT VOLLKOMMEN VERSTEHEN, WENDEN SIE SICH BITTE AN DEN HERSTELLER FUER RICHTIGE HILFE EHE SIE VERSUCHEN DIESES PRODUKT ZU OPERIEREN.

SI VOUS NE LISEZ OU NE COMPRENDRE ENTIEREMENT LES MATIERES DE CE MANUEL, S'IL VOUS PLAIT, CONTACTEZ L'USINE POUR L'ASSISTANCE APPROPRIEE AVANT D'UTILISER LE PRODUIT.

IMPORTANT:

- DO NOT allow anyone to operate Auger without first reading this Operator Manual and becoming familiar with Auger operation.
- Manufacturer of this Auger has gone to great extremes to provide owner(s) and/or operator(s) with the finest equipment available for its intended job function of digging vertical holes in unconsolidated and specific semi-consolidated earth formations. Yet, the possibility exists Auger can be utilized in and/or subjected to job applications not perceived and/or anticipated by manufacturer. Such misuse and/or misapplication of Auger can lead to possibility of serious damage, injury or even death.
- It is responsibility of owner(s) and/or operator(s) to determine Auger is utilized and/or operated within scope of its intended job function.
- It is responsibility of owner(s) and/or operator(s) to establish, monitor and constantly upgrade all safety programs and/or practices utilized in and for operation of Auger. Purpose of such programs is to provide for owner(s) and/or operator(s) safety. Operators must be instructed to recognize and avoid unsafe conditions associated with their work (29 CFR 1926.21 (b)(2)) and/or applicable updated revisions.

OPERATOR INSTRUCTIONAL DATA SHEET

The following undersigned operators of Auger described and/or pertaining to this Operator Manual have received formal safety and operational information/instruction from undersigned owner(s)/instructor(s) in accordance to OSHA 29 CFR 1926.21 (b)(2) and/or applicable updated revisions pertaining to, but not necessarily limited to the:

1. READING, COMPREHENSION AND ACKNOWLEDGEMENT OF MATERIAL COMPRISING ENTIRE CONTENTS OF APPLICABLE OPERATOR MANUAL.
2. FORMALIZED OPERATOR SAFETY PROGRAM TO BE DEvised BY OWNER OF AUGER IN CONJUNCTION WITH CONTENTS OF APPLICABLE OPERATOR MANUAL FOR AUGER.
3. OSHA RULES AND REGULATIONS RESEARCHED FOR AND/OR BY OWNER OF AUGER AND DEEMED APPLICABLE TO SAFE AND PROPER USE AND/OR OPERATION OF AUGER FOR ANY SPECIFIC JOB APPLICATION.
4. LOCAL LAWS, REGULATIONS AND CUSTOMS RESEARCHED FOR AND/OR BY OWNER OF AUGER AND DEEMED APPLICABLE TO SAFE AND PROPER USE AND/OR OPERATION OF AUGER FOR ANY SPECIFIC JOB APPLICATION.
5. FORMALIZED MAINTENANCE PROGRAM FOR AUGER TO BE DEvised BY OWNER OF AUGER IN ACCORDANCE WITH, BUT NOT NECESSARILY LIMITED TO, SPECIFICATIONS, GUIDELINES AND OPERATIONAL INFORMATION CONTAINED IN APPLICABLE OPERATOR MANUAL.
6. COMPREHENSIVE OPERATIONAL INSTRUCTIONS FOR CORRECT AND PROPER USE OF AUGER AS PER CONTENTS OF APPLICABLE OPERATOR MANUAL.

_____	Operator	_____	Owner/Instructor	_____	Date
_____	Operator	_____	Owner/Instructor	_____	Date
_____	Operator	_____	Owner/Instructor	_____	Date
_____	Operator	_____	Owner/Instructor	_____	Date
_____	Operator	_____	Owner/Instructor	_____	Date
_____	Operator	_____	Owner/Instructor	_____	Date
_____	Operator	_____	Owner/Instructor	_____	Date
_____	Operator	_____	Owner/Instructor	_____	Date
_____	Operator	_____	Owner/Instructor	_____	Date
_____	Operator	_____	Owner/Instructor	_____	Date
_____	Operator	_____	Owner/Instructor	_____	Date
_____	Operator	_____	Owner/Instructor	_____	Date
_____	Operator	_____	Owner/Instructor	_____	Date
_____	Operator	_____	Owner/Instructor	_____	Date
_____	Operator	_____	Owner/Instructor	_____	Date
_____	Operator	_____	Owner/Instructor	_____	Date
_____	Operator	_____	Owner/Instructor	_____	Date

NOTE: INSERT COPIES OF THIS PAGE WITHIN OPERATOR'S MANUAL IF SPACE FOR ADDITIONAL OPERATORS IS REQUIRED.

1 INTRODUCTION

Congratulations on your decision to purchase a Brave light construction product. It has been a continuing objective of Brave to manufacture equipment that delivers uncompromising value, service life and investment return.

When you purchased this product, you also gained access to a team of dedicated, knowledgeable, support personnel that stand willing and ready to provide field support assistance. Our team of sales representatives and in-house factory personnel are available to ensure each Brave product delivers the intended performance and product safety you expect. Our personnel can readily answer your questions or concerns regarding proper applications, service requirements and warranty related problems.

If you have any questions or concerns about this product, please feel free to contact our Customer Service Department during normal business hours using the contact information located on the front cover of this manual. There is no charge for this service.

Sincerely,
The Brave Team

2 INTENDED USE

The Auger is intended for use in digging holes outdoors in a variety of soil conditions from soft loams to hard-packed caliche. The machine is operated by one adult of proper operator experience/skill/common sense, height, weight, strength and physical condition. Minors should never be allowed to operate the Auger.

Auger is classified as a low cost, hand held, low horsepower, portable type machine. The number of practical and/or suitable job applications for this type equipment is limited. Particular job application variables and operator experience/skill/common sense may require a different type machine, method and/or process to properly complete job efficiently and safely. Contact Customer Service Department for specific information regarding suitable job applications, job sites, soil conditions and operator experience/skill/common sense recommendations for Auger BEFORE utilization.

Never exceed the recommended capacities of Auger. Refer to BEFORE OPERATING and SPECIFICATIONS sections in this manual for more detailed information. Always utilize correct auger bit and auger bit extension series designed for use with Auger. DO NOT use ice augers to dig earth. Use of an incorrect auger or auger bit series can result in property damage and/or personal injury.

OPERATIONAL DISCLAIMER

The manufacturer of this Auger makes no warranty or guarantee it is merchantable and/or suitable for a specific job application and that it will have the power required to dig a specific diameter hole down to a specific depth in a specific soil classification.

3 TRAINING

Develop a comprehensive program for safe Auger operation by owner(s) and/or operator(s). Program will include, but is not limited to: instructional operation requirements, applicable OSHA requirements, local laws and regulations, job site safety plus Auger maintenance. Constantly examine and upgrade program to guarantee owner(s) and/or operator(s) safety. Each operator must be fully instructed regarding specifics of this safety program.

4 SAFETY SYMBOLS

SAFETY ALERT SYMBOL & SIGNAL WORDS

The safety alert "general warning" symbol indicates a potential personal injury hazard. A signal word (DANGER, WARNING, or CAUTION) is used with the alert symbol to designate the degree or level of hazard seriousness. Other safety symbols may be used to represent the type of hazard in combination with "general warning" symbol, in highlighted boxes, or individually.

DANGER:

Indicates a hazard with a high level of risk which, if not voided, *will* result in death or serious injury.

WARNING:

Indicates a hazard with a medium level of risk which, if not avoided, *could* result in death or serious injury.

CAUTION:

Indicates a hazard with a low level of risk which, if not avoided, *could* result in minor or moderate injury.

The following safety alert symbols identify important safety messages in this manual. When you see these symbols, be alert to the possibility of personal injury and carefully read the message that follows.

SAFETY SYMBOLS & MEANINGS

Symbol	Meaning	Symbol	Meaning
	Action Required		General Warning
	Read Manual		Warning, Flammable Material
	Wear Ear Protection		Warning, Explosive Material
	Wear Eye Protection		Warning, Toxic Material
	Wear Protective Gloves		Warning, Electricity
	Wear Safety Shoes		Warning, Body Entrapment
	No Open Flame		Warning, Rotating Parts
	No Smoking		Warning, Hot Surface
	No Active Mobile Phone		Warning, Floor Level Obstacle
	No Food Or Drink		Warning, Drop Off
	No Trash Containers		Warning, Slippery Surface

5 SAFETY INSTRUCTIONS



WARNING

- These safety instructions provide guidelines to promote safety and efficiency with the Auger.
- No warranty, guarantee or representation is made by manufacturer as to absolute correctness or sufficiency of any information or statement.
- Safety instructions are intended to deal with common practices and conditions encountered in use of Auger and are not intended to be all inclusive.
- Not following instructions in this manual can result in property damage, personal injury and/or death.



DANGER



- This product can expose you to chemicals including greases, lubrication oils, silica dusts and asbestos which are known to the State of California to cause cancer and carbon monoxide (if gasoline engine driven) which is known to cause birth defects or other reproductive harm. For more information: www.P65Warnings.ca.gov

SPARK ARRESTER DISCLAIMER



WARNING

- **DO NOT operate Auger on any forest covered, brush covered, or grass covered, unimproved land unless an approved spark arrester is installed on the muffler. The spark arrester must be maintained in proper working order by the owner and/or operator. In the State of California, the above is required by law. Other states may have similar laws. Laws will apply on US Federal lands. Laws will vary with use in specific countries.**

BEFORE OPERATING



1. BEFORE operating the Auger, read this manual plus applicable safety/operational information supplied by engine manufacturer to familiarize each operator with correct operating procedures.
2. Visually inspect Auger per MAINTENANCE INSTRUCTIONS STEPS 4 through 15 of this manual.
3. Determine Auger is in original, factory configuration and has not been modified in any manner. If questions arise about possible modifications, contact the Customer Service Department BEFORE utilization. There is no charge for this service.
4. Always start and stop Auger according to instructions to minimize possibility of unexpected or uncontrolled auger bit rotation. Know how to stop unit in an emergency.

Physical Exertion/Body Strain

Operating the Auger requires proper physical stamina, mental alertness and is strenuous. Operator must be in proper physical condition, mental health and not under the influence of any substance (drugs, alcohol, etc.) which might impair vision, dexterity or judgement. Take work breaks to maintain stamina and alertness. If you have condition(s) that might be aggravated by strenuous work, check with doctor BEFORE operating.

Operator

Operator must be of adequate height for any given operating configuration and operator handle must remain below their shoulder sockets. DO NOT operate Auger if this condition is not satisfied. Auger requires operator to be of adequate height, weight and strength to maximize digging efficiency and minimize possibility of personal injury.

Vibration

Prolonged use of Auger (or other, similar machines) exposes operator to vibrations which may produce Whitefinger Disease (Raynaud's Phenomenon) reducing hand's ability to feel and regulate temperature, produce numbness and burning sensations plus may cause nerve, circulation damage and tissue necrosis. Continuous and regular users should closely monitor condition of hands and fingers. After each period of use, exercise to restore normal blood circulation. If any symptoms appear, seek medical advice immediately.

Noise

Auger and actual digging process creates exposure to high noise emission levels that can result in hearing loss or damage. Hearing protection is required while operating or when near operating equipment. Continuous and regular operators should have hearing checked regularly.

Poisonous Gas

Auger is powered by a gasoline engine which produces Carbon Monoxide fumes during combustion process. Carbon Monoxide fumes are poisonous. If Auger is operated in closed area (indoors or outdoors), determine if supplemental ventilation is required to minimize potential effects of Carbon Monoxide to operator. Follow all current OSHA regulations for ventilation.

Clothing

Clothing must be sturdy, snug fitting, but allow complete freedom of movement. Never wear loose fitting jackets, scarves, neckties, jewelry, flared or cuffed pants or anything that could become caught on controls or moving parts. Properly secure eyeglasses, hearing aid devices and other medical related devices. Wear long pants to protect legs. Protect hands and improve grip with heavy duty, nonslip gloves. Wear and properly lace sturdy boots with nonslip soles. Steel-toed safety shoes are mandatory. Wear approved safety hard hat where there is danger of head injuries.

Flying Debris

Hole digging process can result in flying debris. Eye protection and appropriate safety apparel is required when near or operating Auger. DO NOT operate unit with onlookers or animals close by.

Burns

An engine muffler can become hot. Remain clear of and DO NOT touch a hot muffler or heat shield.

Auger Entrapment

Auger bit is not shielded. Keep body and all foreign objects clear of rotating auger bit.

BACK CARE & PROPER LIFTING PROCEDURES

Operator will be required to lift Auger, auger bit/auger bit extension repetitively as demanded by specific job applications. When lifting, one person is required. Utilize proper lifting techniques to minimize fatigue and back-related injuries.

Back Anatomy

The human body is supported by the spinal column consisting of thirty bones called vertebrae, all linked and supported by a series of muscles. Pads called discs separate each vertebrae, acting as cushions to pressure from external forces. Spinal column is wrapped by nerve system with three sections that require being kept in natural alignment to prevent discomfort:

- Cervical: From base of neck to brain.
- Thoracic: From middle to lower back.
- Lumbar: From lower back to buttocks area.

Back Care Preventative Measures

Most occupational physicians agree on several "universal" preventative measures an operator should follow to help lower risk of back-related injuries:

1. Maintain proper body weight.
2. Eliminate/reduce use of tobacco. Smoking reduces oxygen supply and nutrients to discs cushioning vertebrae.
3. Develop a consistent exercise routine.
4. Maintain good posture while walking or sitting.
5. Watch how you twist/bend your body. Twisting/bending incorrectly can exert too much pressure on discs and vertebrae.
6. Use firm footing, keep intended path clear before carrying Auger.
7. Always use proper lifting techniques as described below.

PROPER LIFTING PROCEDURES

The following are guidelines for properly lifting Auger and auger bit/auger bit extension from hole and are not intended to be all inclusive. Plan your path and make sure there are no obstructions or tripping hazards. Consider how you will set the load. The spinal column is a very sensitive mechanism. At any given time, improper lifting procedures can cause damage that can lead to injury.

1. Position feet a comfortable distance (shoulder width) apart to help provide necessary balance.
2. Tighten stomach muscles by pulling in your stomach. Keep back as straight as possible to keep spine, back muscles/ligaments in alignment.
3. Bend at hips and knees as much as possible.
4. Start lifting Auger by thrusting feet while lifting as much as possible with leg muscles. Use smooth movements.
5. Once Auger is lifted, keep it close as possible to the body. Avoid turning at waist. To turn, pivot entire body.
6. Keep shoulders, hips and feet pointed in same direction.

IMPORTANT: Use firm footing, keep intended path clear before carrying Auger.

TRANSPORTATION



1. Auger is designed for one operator to transport it by the operator handle to, while on, and from job site.
2. When transporting Auger in/on motor vehicle, gasoline tank breather vent (if so equipped) must be completely closed to eliminate fuel seepage.
3. To minimize damage to Auger, transport in vehicle to job site with auger bit disconnected and operator handle level with transport surface. This prevents crankcase oil entering combustion chamber causing hydraulic lock up.
4. DO NOT allow operator handle to contact auger bits, shovels, or other sharp/abrasive objects during transit or drop Auger to prevent damage to unit.
5. All equipment must be secured in/on vehicles with suitable strapping or tie downs.
6. Personnel should not be transported in same compartment as equipment and fuel supplies. Consult applicable OSHA regulations for specific information.



CAUTION

- Improperly secured Auger and related accessories can fall from moving vehicle and result in property damage and/or personal injury.

DETERMINATION OF POTENTIAL SUBSURFACE HAZARDS IN PROPOSED DIGGING LOCATION(S)



Auger operator handle and throttle control are constructed of metallic and a non-metallic, composite material and does not guarantee operator will be properly insulated from contact with charged electrical cables. Auger and related accessories are not classified as insulated.

Auger is not sealed or insulated. DO NOT operate Auger in an explosive atmosphere or near combustible materials. Refer to current OSHA rules and regulations.



WARNING



BEFORE attempting to dig any holes, identify/mark all potential subsurface hazards in proposed digging locations(s). Potential subsurface hazards may include, but may not be limited to the following:

1. Rocks and roots of any size.
2. Differences and/or variances in specific soil classifications.
3. Buried garbage/other debris.
4. Buried pressurized pipelines (e.g. natural gas, propane, etc.)
5. Buried electrical cables.



DANGER



- Always assume digging location contains buried underground obstructions.
- BEFORE attempting to dig any holes in proposed location(s), call 811 and/or visit www.Call811.com.
- Contact appropriate agencies to determine exact location(s) of all buried pipelines, powerlines and material debris.
- Many utilities and other agencies will perform these tasks at minimal charge or at no cost. Have all subsurface hazards marked for easy recognition.
- Direct contact with these and other subsurface hazards can result in property damage and/or personal injury through such things as electrocution and/or explosion.

DETERMINATION OF POTENTIAL ABOVE SURFACE HAZARDS IN PROPOSED DIGGING LOCATION(S)



Normal Auger use is on level ground. Avoid other terrains which can be dangerous. Special care must be exercised on overgrown, slippery, and/or difficult/uneven terrain. Watch for surface irregularities. Remove any trip/fall hazard, grass or other overgrowth BEFORE operating Auger. Operate only when/where visibility and light are adequate for job at hand. Keep proper footing and balance at all times. Engine/engine muffler can become extremely hot with potential to burn operator and/or ignite dried materials such as leaves, grass, etc. Remove such materials where digging with or placing Auger.

OPERATIONAL HAZARDS UNDERSTANDING KICKBACK



Torque and kickback generated by digging process is common with portable, one-man hole diggers. Auger engine torque is transmitted and multiplied by transmission to auger bit. When auger bit contacts a buried obstruction, left side of operator handle is "thrust" towards operator in a sharp, sudden, counter-clockwise rotation. "Thrusting" force is called kickback and varies depending on speed of handle movement. Kickback force can have magnitude to "throw" operator from Auger and/or inflict damage to hands, arms, and other upper body parts.

Preventive Measures:

- Operator must maintain physical and mental alertness. Be prepared for unexpected auger contact with buried tree roots, rocks, etc., and be capable to sense level of machine control they have.
- Maintaining proper operating stances and applying reactive "body english" is one of the most IMPORTANT and EFFECTIVE procedures to control kickback. Refer to OPERATOR STANCES in OPERATING INSTRUCTIONS section of this manual for more information.
- "Spinning" about axis is caused by improper engine throttle control adjustment. Refer to MAGURA® THROTTLE CONTROL MAINTENANCE PROGRAM in MAINTENANCE INSTRUCTIONS section of this manual to correct situation BEFORE placing machine back into service.



CAUTION

- Always assume every digging site can include some form of buried obstruction. Always be prepared for unexpected auger bit contact with buried tree roots, rocks, etc.
- Under certain operating conditions, striking a buried obstruction can produce a severe and/or sudden kickback force to hip and/or leg areas.
- Force can have magnitude to "throw" operator from Auger.
- Failure to properly accommodate this phenomenon can result in property damage and/or personal injury.



WARNING



If, during hole digging process, operator loses full control of Auger for any reason, the following procedure is suggested:

- As a general rule, as soon as operator realizes they are in process of losing control of Auger, they should "push" themselves free and clear from operator handle.
- Procedure requires operator fully comprehends they are losing control of Auger and to react accordingly with appropriate body movement.
- Improper reactions to this phenomenon can result in property damage and/or personal injury.

WARNING

- An Auger with improperly maintained engine throttle control will “spin” about its axis when operator loses full control.
- In event of this occurrence, do not attempt to stop engine by grasping rotating operator handle.
- DO NOT introduce any foreign object in an attempt to stop and/or block rotating handle. Instead, allow engine to exhaust its fuel supply.
- Determine that all components of engine throttle control assembly allow for proper function before attempting to further utilize Auger.

MINIMIZING KICKBACK FROM A DESIGN STANDPOINT

1. Auger features the widest operator handle of any machine of its type and/or class. Handle is biomechanically positioned to enhance control, allowing operator to exert “body english” against torque and kickback forces generated by digging process.
2. Auger features an operator handle with an antivibration PVC coating and handle mounts that enhance control and help dampen vibration, torque and kickback experienced by operator during digging process.
3. Auger utilizes a twist grip throttle control. Throttle control was selected over other configurations (for operator handle configuration utilized and specific digging power) to allow operator to wrap his/her thumb and forefinger around for effective maximum strength in his/her right hand. Design provides greater operator machine control when counteracting torque and kickback forces during digging process.
4. Auger is designed to utilize Brave PN BR10628 auger pin for auger bit retention to transmission driveshaft. Pin is not intended to shear and absorb kickback related forces when auger bit comes in sudden contact with buried object.
5. Auger pin is utilized for the following reasons:
 - a. Pin shear would result in extensive physical damage to driveshaft and auger drive hub.
 - b. Potentially unknown/large pin quantity could be required to complete digging of any specific hole even if physical damage to Auger could be eliminated and/or minimized.
 - c. Even if replacement auger pin costs are not a factor, resulting productivity produced by actual process would not be acceptable by industry and/or social standards for Auger.
 - d. Given infinite number of potential operators and methods utilized during digging process, it is impossible to design and supply specific auger pins to shear at a specific torque value and produce acceptable operational results for Auger.
 - e. Given infinite number of potential soil conditions, auger bit diameter, auger bit boring head condition, digging depth, mechanical operating conditions, operators and operator methods encountered during digging process, it is impossible to design and supply specific auger pins to shear at a specific torque value and produce acceptable operational results for Auger.
6. For comparison purposes, portable electric screwdrivers and drills can utilize a torque limiting or clutch device to allow drill chuck to slip at a limited number of specific torque values. For an Auger, such a device would make the Auger useless due to infinite number of potential operating configurations required and inability to design specific components to meet requirements of each operating configuration.
7. Portable screwdrivers and drills are separate tools designed for different and specific job applications. The drilling process has different requirements than the fastening process for screwdrivers. Portable electric screwdriver and drill operational characteristics cannot be confused and/or substituted for Auger operational characteristics.

6 MACHINE SPECIFICATIONS

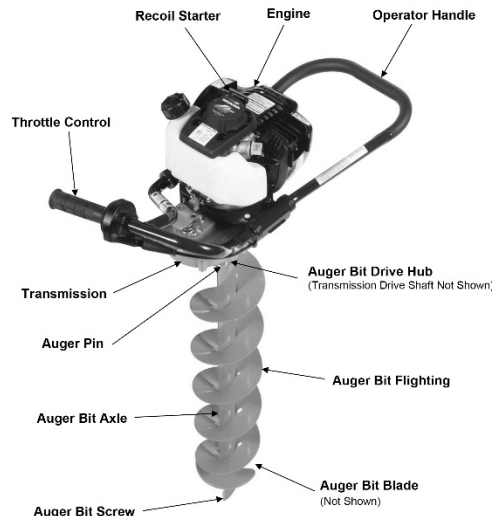

FIGURE 1

ENGINE TYPE	Honda GX35
HIGH SPEED	9000 RPM (No Load)
IDLE SPEED	2900 RPM
SPARK PLUG GAP	.030 inch (.762 mm)
FUEL	Unleaded, “regular” grade gasoline (RON 87). Consult engine manufacturer supplied materials for specific information.
FUEL TANK CAPACITY	22 US ounces (0.64 L)
TRANSMISSION TYPE	Enclosed, spur geared, double reduction
REDUCTION RATIO	42.5 to 1
LUBRICANT CAPACITY	8 US ounces (224 g)
LUBRICANT SPECIFICATION	High temperature transmission grease containing an extreme pressure (EP) additive. 3 inch (76 mm) diameter, automatic type centrifugal.
CLUTCH	
MACHINE WEIGHT	28 lbs (13.0 Kg) (less auger)
AUGER CAPACITY	2 inch (50.8 mm) diameter up to and including 8 inch (203 mm) diameter. Refer to DIGGING OPERATION section in this manual for specific information.
OPERATING ENVIRONMENTS	Non-hazardous type locations.
REQUIRED NUMBER OF OPERATORS	1

NOISE & VIBRATION EMISSIONS

Description	North America	Europe
Model	BRPA180H	
Noise Level	85 db	
Vibration Level	51 m/s ²	

7 STANDARD PRODUCT & ACCESSORIES

Refer to FIGURE 1 for overview description of standard components included in machine. Included in shipment for Auger should be the following:

- 1 each, engine/transmission assembly
- 1 each, auger pin
- 1 each bottle of engine oil
- 1 each, operator manual
- 1 each, applicable engine manual
- 1 each, final inspection form

ACCESSORIES

NOTE: All auger bits, bit extensions, blades and bit screw are for use in general purpose projects for a variety of soil conditions unless otherwise specified. All auger bits and auger bit extension drive connections are 1 inch (25 mm) diameter. Digging depth for all augers is 30 inch (762 mm) and auger extension is 15 inch (381 mm).

	Part #	Description	Cutting Diameter	Weight (in lbs)
	BR10639	2.25 inch (57 mm) Auger OD	2.50 inch (64 mm)	8.0
	BR10640	3.25 inch (83 mm) Auger OD	3.50 inch (89 mm)	9.0
	BR10641	4 inch (102 mm) Auger OD	5.2 inch (133 mm)	12.0
	BR10642	6 inch (152 mm) Auger OD	7.5 inch (191 mm)	14.0
	BR10643	8 inch (203mm) Auger OD	9.5 inch (241 mm)	18.0
	BR10645	No Flighting Auger Bit Extension	NA	3.6
	BR10631	4 inch (102 mm) Auger Blade	NA	0.5
	BR10632	6 inch (152 mm) Auger Blade	NA	0.8
	BR10633	8 inch (203 mm) Auger Blade	NA	1.1
	BR10634	10 inch (254 mm) Auger Blade	NA	1.2
	BR10635	12 inch (304,8 mm) Auger Blade	NA	1.5
	BR10636	Auger Screw Bit, BR10640 ONLY.	NA	1.6
	BR10637	Auger Screw Bit, BR10639 ONLY.	NA	3.0
	BR10621	Auger Screw Bit, all other augers.	NA	4.2
	BR10628	Auger Pin	NA	0.4

8 MACHINE SET-UP



Open shipping carton immediately upon receipt. Remove Auger from carton. Visually inspect contents of carton for freight damage and/or missing parts. If shipping damage is evident, contact delivering carrier immediately to arrange for an inspection of damage by their claims representative. **DO NOT DESTROY OR DISCARD SHIPPING CARTON UNTIL INSTRUCTED BY AUTHORIZED REPRESENTATIVE OF CARRIER OR FACTORY.** If missing parts are detected, notify your dealer who will assist you in obtaining them.

ASSEMBLY

Auger is shipped from factory completely assembled. The transmission is lubricated at the factory and will not require further servicing prior to initial usage.

1. Visually inspect throttle control, throttle cable assembly and carburetor for signs of damage. Rotate throttle control to determine carburetor spring allows carburetor throttle lever to travel from its low to high speed position and back again without any restriction and/or binding.



WARNING

- Determine all components of engine throttle control assembly allow for proper function.
- Throttle lever of carburetor must return engine to idle speed, as stated in MACHINE SET-UP section of this manual, when twist grip throttle is released by operator.
- If proper function does not occur, contact your dealer or customer service department for specific information to correct the situation.
- DO NOT operate Auger until improper function has been corrected.
- An improperly functioning throttle control can result in property damage and/or personal injury.

2. Check all fasteners for security, tighten as required.

>>>> BEFORE STARTING ENGINE <<<<

FILLING ENGINE FUEL TANK



Tools Required:
1 each, small, clean funnel.



CAUTION



- Never mix oil with gasoline for use in a 4 cycle engine. Damage to engine can result. Four cycle engines do not utilize oil mixed with gasoline for lubrication purposes.

BEFORE operating Auger refer to MACHINE SPECIFICATIONS section in this manual and engine manufacturer supplied materials for information regarding engine fuel, fueling and lubrication requirements.

1. Use extreme caution handling gasoline. Always use UL, CSA or UN marked, European ADR regulation approved container for storage and transportation of fuel. Shut engine off and allow to cool before fueling. Never remove fuel tank filler cap or fill fuel tank while engine is running. Never operate engine without fuel tank filler cap. Select bare ground for fueling and move at least 10 feet (3.05 M) from fueling spot before starting engine.
2. Carefully clean filler cap and surrounding area to prevent dirt/debris falling into fuel tank.
3. Fill fuel tank with fresh, clean, unleaded automotive gasoline. Leaded "regular" grade gasoline is acceptable substitute. DO NOT USE GASOLINE CONTAINING METHANOL (WOOD ALCOLHOL). Gasoline containing maximum 10 percent ethanol/grain alcohol (sometimes referred to as Gasohol) may be used but requires special care when storing engine for extended periods.

NOTE: DO NOT use gasoline left over from previous season for easier engine start-up and prevent poor engine performance.

4. DO NOT completely fill tank. Fill tank to within 1/4 inch (7 mm) to 1/2 inch (13 mm) of tank top to allow for fuel expansion. Replace filler cap. Wipe any fuel spillage and oil if leak is detected from engine and Auger BEFORE operating engine. DO NOT operate engine until leak is fixed plus, fuel and oil are wiped away. Properly dispose of any fuel or oil wiped from machine/rags per international and local regulations. DO NOT allow fuel or oil to get on clothing. Change clothes immediately if this happens.

 **DANGER** 

- **DO NOT smoke near fuel tank.**
- **DO NOT fill fuel tank with engine running or if it is hot.**
- **Allow ample time between each refueling for engine to cool.**
- **An ignition source in close proximity to fuel tank can be the source of an explosion, resulting in property damage and/or personal injury.**
- **Consult material supplied by engine manufacturer for information relative to proper fueling procedures.**

9 APPLICATION THEORY & TECHNIQUES



The Auger operates on principle of accessory auger bits attached to the transmission drive shaft to rotate and dig holes in a variety of soil types. The combination of auger bit diameter, blade, screw bit, soil type and down pressure supplied by operators will affect the hole digging rate.

Hole digging process is directly controlled by:

1. Soil type.
2. Auger bit boring head design and diameter selected.
3. When required, sufficient application and/or reduction of machine weight and/or down force provided by operators to assist auger bit soil penetration.
4. No two soil types are exactly alike, no two holes can be dug by exact same method, overall operator feed rates vary. The hole digging process, along with operator experience, skill and common sense, suggests hole digging is a matter of trial and error and directly determines overall success of the job application.

HOLE DIGGING TECHNIQUES

1. Normal Auger operation runs engine at full, governed speed allowing centrifugal clutch to become firmly engaged. Technique transmits more usable power to auger bit, increasing productivity and reducing component wear. For any soil condition, allow auger bit to dig at rate most comfortable to operator, but not cause centrifugal clutch to overload and slip.

NOTE: Auger is equipped with a centrifugal clutch assembly within the transmission. The clutch assembly is designed to ALWAYS slip (NOT DISENGAGE) when overloaded or if auger bit contacts buried obstruction. When slipping, clutch still transmits a specific amount of torque to auger bit. Response time for clutch to react to overload condition is directly proportional to rotational speed. With higher rotational speeds (RPM) of clutch at time of overload, it takes more time for clutch to react and actually slip.

 **CAUTION**

- Improper operating procedure can allow auger bit to "bind" and/or "bury" itself in the hole.
- This is usually the result of allowing auger bit to feed at an excessive rate. Phenomenon is also characteristic of digging with smaller diameter (2 to 4 inch) augers.
- In this condition, Auger is not capable of transmitting ample power to "free" auger bit.
- **DO NOT** continue to overload and slip centrifugal clutch assembly.



2. In general, pressing down on operator handle is not required to initiate and/or sustain the digging process. In most moderate density soils, auger bit dig rates will not cause centrifugal clutch to overload and slip. In most soft, low density soils (sandy, etc.), it may be necessary to hold up on operator handle to reduce auger bit dig rate due to tendency of any auger bit design to cause centrifugal clutch to overload and slip. In most hard, high density soils (hard clay, etc.), it may be necessary to press down on operator handle to establish and maintain acceptable dig rates.

3. Some soil conditions may require more power to dig than machine is capable of delivering for a given auger bit diameter. To minimize problem, apply suitable down force by operator and use auger bits with new bit screws and blades. **DO NOT** use more than one operator to apply down force. If it is felt more than two operators are required to apply down force, **STOP** and contact Customer Service Department for operational recommendations.
4. When digging in areas filled with known, buried obstructions such as tree roots, rocks and other debris, operate Auger at less than full (an intermediate) speed for more rapid release of centrifugal clutch when obstruction is encountered. This is an industry wide operating procedure.
5. When digging in areas filled with small tree roots, small rocks or other buried obstructions, allow auger bit blade to "chip away" at obstruction until auger bit can pass by (by working object loose) or go through it (as in penetrating tree roots). Technique usually involves holding up on operator handle using minimal auger bit feed rate. Many times, size and nature of buried object will prevent auger bit from passing by or going through it. Instead, remove buried object with shovel or other suitable tool and proceed to dig to desired depth using Auger.

 **CAUTION**

- Some job applications may encounter buried obstructions too massive in size or soil classifications too compacted to allow use of machine the size and/or with operating limitations of Auger.
- Utilization of Auger on these work sites can cause property damage and/or personal injury.
- Exercise proper common sense by selecting proper size and/or type equipment for the job application.

6. In most soil conditions, the auger bit will retract with less effort if allowed to rotate at slow speed. This procedure, however, will leave more loose soil at bottom of hole. To minimize amount of loose soil remaining at bottom of hole, stop rotation before retracting auger bit.
7. When restarting Auger with auger bit in a partially or completely dug hole extra caution is required. The throttle control can be advanced beyond idle speed before operator can exercise proper control of Auger. The accepted procedure (when not using non-flighted auger bit extension) is to first remove unit from hole and restart engine per **STARTING ENGINE WITH AUGER BIT ATTACHED IN OPERATING INSTRUCTIONS** section of this manual. Return unit to hole with engine at idle speed and complete hole to desired depth.

 **CAUTION**  

- Restarting engine with auger bit in partially or completely dug hole requires higher degree of operator experience, skill and common sense over introductory or novice level expertise.
- Manufacturer is aware many operators restart Auger's engine with auger bit in partially or completely dug hole on regular basis while in the field.
- Manufacturer also realizes procedure must be utilized when auger bit extension is used to extend digging depth. Manufacturer has no control over experience, skill and common sense levels of each operator of the Auger.
- Manufacturer has no control over each job site or specific job application for the Auger.

8. Grass and other overgrowth conditions will hamper digging capability of any auger by becoming "clogged" around auger teeth and screw bit. Removal of such obstructions from hole location **BEFORE** digging will increase digging efficiency and overall productivity.

 **CAUTION**

- **DO NOT** dig initial hole with smaller auger bit then use larger diameter auger bit to "ream" hole to desired size.
- This method will prevent auger bit screw of larger auger bit from providing sufficient directional stability during "reaming" process.

WARNING   

- **DO NOT** use shovel and/or foreign object to remove loose soil from around hole area while operating Auger.
- This can result in shovel and/or foreign object to become entrapped by rotating auger bit.



10 OPERATING INSTRUCTIONS



IMPORTANT: DO NOT operate Auger until each operator completely comprehends contents of this manual, plus applicable safety and operational information supplied by engine manufacturer.

INSTALLING AUGER BIT

1. Refer to STOPPING AUGER in OPERATING INSTRUCTIONS section of this manual. To install auger, place Auger with spark plug facing up.

DANGER   

- **DO NOT** connect auger bit to Auger with engine running.
- A sudden change in engine speed will result in property damage and/or personal injury.

2. Connect auger bit to Auger with correct factory supplied auger pin.

CAUTION 



- When installing auger bit and auger pin, always place Auger with engine spark plug in upward position to minimize potential for oil and/or gasoline to enter combustion chamber and create a hydraulic lock up.
- Such occurrence can result in property damage and/or personal injury.

CAUTION 



- DO NOT use any other connecting device except auger pin supplied with Auger which is designed to withstand high stresses encountered while digging.
- Use of any other connecting device, including cap screws, bolts, pins, etc., can result in damage to Auger driveshaft and/or auger bit drive hub.
- Improper connecting devices can cause property damage and/or personal injury.

STARTING ENGINE WITH AUGER BIT ATTACHED



DO NOT attempt to dig with Auger until operator is ready and is in full control of machine/accessories.

DANGER   

- **Auger is designed for one operator. Use by more than one operator will lead to confusion and loss of control, resulting in property damage and/or personal injury.**
- **Start engine according to instructions outlined below to minimize possibility of unexpected auger bit rotation.**
- **Unexpected auger bit rotation can result in loss of machine control and possibility of property damage and/or personal injury.**

DANGER   

- To reduce potential for personal injury, stop Auger between each hole.
- **DO NOT** choose to save time (time required to restart engine), money (if Auger is being rented) or gain added convenience by electing to keep engine running between each hole.
- Actions can lead to loss of control, resulting in property damage and/or personal injury.

WARNING   

- Auger controls are designed for operator to choke and start engine with left hand while operating throttle control with right hand.
- With this intended operating position, the engine exhaust muffler faces away from operator, directing fumes and heat in opposite direction from operator.
- **DO NOT** operate Auger with engine exhaust muffler/shield facing toward operator. This operating position will allow operator to come in contact with hot surface of engine muffler/shield and allow operator to inhale high levels of carbon monoxide resulting in property damage and/or personal injury.

CAUTION 

- If Auger and/or an individual component/accessory does not appear to function properly, STOP and DO NOT operate Auger until corrective action has been completed.
- If you have any questions regarding proper operation of Auger, contact Customer Service Department for assistance BEFORE using. There is no charge for this service.

3. Place Auger in vertical orientation on desired hole location so right hand operates throttle control.
4. With left hand, open fuel tank breather vent (if so equipped) to its maximum set position. Failure to open breather vent prevents engine from receiving continuous supply of fuel.
5. Gripping operator handle on left side with left hand, use right hand to turn engine ON/OFF ignition switch to ON position. FIGURE 2



FIGURE 2

6. With left hand, depress engine primer system bulb repeatedly until fuel can be seen in clear plastic fuel line and primer bulb. FIGURE 3



FIGURE 3

7. If engine is cold or the ambient temperature is low, using left hand, move choke control lever to the left/closed position (away from fuel tank). A warm (previously run) engine may not require choking. FIGURE 4



FIGURE 4



CAUTION

- Proper choke lever operation moves in a sideways motion as viewed by the operator.
- DO NOT move choke lever in a fore and aft direction, such action can result in damage to choke control mechanism.
- DO NOT apply excessive force when moving choke lever. Excessive force can damage carburetor.

8. Grip throttle control with right hand. It is not necessary to rotate the throttle control to start the engine.
9. Using left hand, pull engine starter recoil handle slowly, until resistance is felt (this is the compression point), then give a fast, short, steady pull. Allow starter rope to retract slowly. DO NOT pull rope out to its maximum, extended length. If engine does not start in three pulls, consult material supplied by engine manufacturer for specific information.

NOTE: Normally, engines not running for some time require three to five pulls to start. Recently run engines usually start on first or second pull. In cold weather, initial starting will require additional pulls due to extremely rich fuel/air mixture.

10. Allow engine to properly “warm up” and operate without requirement for engine choke. Check for proper centrifugal clutch operation, excessive transmission noise and/or vibration.
11. Rotate throttle control counterclockwise to increase engine speed/regulate digging process. Auger begins rotation when centrifugal clutch reaches initial engagement speed.

PROPER OPERATOR STANCE (FIGURE 5 & 6)

12. Grasp operator handle and throttle control firmly. Wrap fingers around handle and throttle control grip, keeping both cradled between thumbs and forefingers.
13. Keep wrists as perpendicular to operator handle and throttle control as feasible while digging. Proper wrist position can minimize and/or reduce stress and strain related damage potential to this body area, plus, operator control is enhanced and fatigue reduced. FIGURE 6

14. Keep left side of operator handle as close to waist/leg/arm areas as possible for maximum leverage/control and minimize effects of “kickback” if obstruction is encountered when digging.
15. Keep arms close to upper body, back as vertical as possible, and bend legs as needed to minimize physical stress.
16. Position left foot forward of right foot and a comfortable distance apart.



FIGURE 5



FIGURE 6

NOTE: Not using a proper operator stance (FIGURES 7, 8, 9):

- a) Reduces operator control and balance.
- b) Increases operator fatigue.
- c) Increases risk of property damage and/or personal injury.



FIGURE 7



FIGURE 8



FIGURE 9

REMOVING STUCK AUGER BIT FROM HOLE

17. Usually due to excessive auger bit feed rate, an auger bit can "bind" and/or "bury" itself in the hole. This is also common when digging with smaller diameter 2 inch (50.8 mm) to 4 inch (101.6 mm) auger bits. When this occurs, **DO NOT** continue to overload and slip clutch assembly. Auger is not capable of transmitting ample power to "free" auger.



WARNING

- **Transmission lock is designed for manual engagement and activation by the operator.**
- **DO NOT use chains and/or slings wrapped around Auger and/or operator handle connected to external towing device such as a truck or loader to remove stuck auger bit.**
- **Improper action can result in property damage and/or personal injury.**

NOTE: The Auger uses a manually deployed transmission lock to prevent gear rotation. Use the following procedure to remove a stuck auger bit from hole:

18. Before attempting to remove stuck auger bit from hole, **STOP** engine per **STOPPING AUGER** in **OPERATING INSTRUCTIONS** section of this manual **BEFORE** moving to step 19 below.
19. Locate transmission lock on top of transmission housing under spark plug/engine cooling fin area of engine. FIGURE 10



CAUTION



- Area can become hot to the touch.
- Wear gloves for added protection.



FIGURE 10

20. Push lock handle down slightly to disengage upper detent position. Turn lock handle counterclockwise (to right) until it stops against vertical slot of lock bracket. FIGURE 10
21. Push lock handle down until it stops against bottom slot of lock bracket and engages transmission gear. (Note, it may be necessary to rotate Auger back and forth slightly to allow lock pin to fully engage gear.) Turn lock handle clockwise (to left) until it stops against right side of slot. Release allowing spring to push handle up into lower detent position. In this position, lock device is fully deployed. FIGURE 11



FIGURE 11

22. Grasp operator handle on both sides and rotate Auger/auger bit counterclockwise (to left). **DO NOT FORCE.** Apply steady pressure until auger loosens in ground, continuing rotation until auger bit is freed from obstruction and Auger/auger bit can be lifted from hole. An additional person may be necessary to assist in this process, one on each side of the widest portion of the operator handle.
23. Inspect Auger/auger bit for damage. Remove any obstruction from auger bit and/or hole.
24. Reverse locking device process to disengage locking pin from gear. Check spring positions handle in upper detent position of locking bracket to prevent inadvertent lock deployment.



CAUTION

- Lock device spring should always be in direct contact with handle in any position.
- If this does not occur, lock device can become inadvertently deployed, resulting in property damage and/or personal injury.
- Replace worn or damaged spring with factory approved replacement part only.

25. Reconnect spark plug wire. Start engine and resume digging process per **STARTING ENGINE WITH AUGER BIT ATTACHED** in **OPERATING INSTRUCTIONS** section of this manual.

ADDING/REMOVING NONFLIGHTED AUGER BIT EXTENSION

For holes deeper than standard augers provide, a non-flighted auger bit extension increases digging depth 15 inches (381 mm). Additional operator experience, over introductory/novice skill levels, is required when using. Follow this accepted procedure to add non-flighted auger bit extension:

26. Dig to approximate full depth of auger bit following operating instructions. Remove as much loose soil from hole as possible per STEP 6 of HOLE DIGGING TECHNIQUES in APPLICATION THEORY & TECHNIQUES section of this manual.
27. STOP Auger per STOPPING AUGER in OPERATING INSTRUCTIONS section of this manual.
28. Remove Auger/auger bit from hole. Disconnect auger bit from Auger. Place auger bit in hole. Attach auger bit extension to auger bit and secure with auger pin. The Auger can now be connected to auger bit extension using auger pin.



FIGURE 13



CAUTION

- Utilization of non-flighted auger bit extensions requires additional operator experience, skill and common sense over introductory or novice level of expertise.
- Manufacturer has no control over experience, skill and common sense levels of each operator of Auger.
- Each operator must decide if his experience, skill and common sense level is sufficient to allow him to proceed with use of non-flighted auger bit extensions for any given and/or specific job application.



WARNING



- **Never utilize more than one non-flighted auger bit extension to increase overall digging depth.**
- **Non-flighted auger bit extensions are not equipped with auger bit flighting to elevate loose borings from hole.**
- **Multiple use of non-flighted auger bit extensions will allow auger bit to "bury" itself in hole. Such use can lead to loss of operator control and/or personal injury.**

29. Per STARTING ENGINE WITH AUGER BIT ATTACHED in OPERATING INSTRUCTIONS section of this manual, dig to desired depth or to full depth of auger extension. To remove auger extension, follow this accepted procedure:
30. STOP Auger per STOPPING AUGER in OPERATING INSTRUCTIONS section of this manual.
31. Remove as much loose soil from hole as possible per STEP 6 of HOLE DIGGING TECHNIQUES in APPLICATION THEORY & TECHNIQUES section of this manual.
32. Lift auger bit extension/auger bit/Auger up far enough out of hole so bottom end of auger extension is clear. FIGURE 12. Block remaining auger with auger fork to prevent falling back into hole. An additional person will usually be required. FIGURE 13



FIGURE 12

33. Disconnect Auger from auger extension. Disconnect auger bit extension from auger bit.
34. Reconnect Auger to remaining auger bit and remove power unit/auger bit from hole. Reconnect spark plug wire.
35. Per STARTING ENGINE WITH AUGER BIT ATTACHED in OPERATING INSTRUCTIONS section of this manual dig next hole based on job application. If project is complete, store Auger per STORAGE section of this manual.

STOPPING AUGER

36. Stop Auger by releasing throttle control grip. Engine should return to the idle speed position. FIGURE 14



FIGURE 14

NOTE: If engine power does not return to the idle speed position, check throttle control grip, throttle cable, and engine throttle control arm for binding and/or improper adjustment.



WARNING



- **Stop Auger between each hole.**
- **Never leave Auger running and unattended.**
- **Not doing so can result in property damage and/or personal injury.**

37. Turn engine ON/OFF ignition switch to OFF position.
38. Disconnect spark plug wire to prevent accidental engine starting.
39. When engine is not in operation or is to be stored, close fuel tank breather vent (if so equipped). Turn fuel tank ON/OFF valve (if so equipped) to OFF position to minimize fuel flooding carburetor and/or entering engine crankcase and/or impacting upon environment.

11 MAINTENANCE INSTRUCTIONS



For routine maintenance, the following information should be followed once per week or 40 hours of use at minimum for maximum performance and return on investment unless otherwise indicated. Information is for reference only and is not intended to be all inclusive.

1. Use factory approved replacement parts/accessories only for maintenance and repair.

WARNING

- **Operating Auger utilizing components not meeting minimum operational standards can result in property damage and/or personal injury.**

2. All maintenance/repairs not described in this operator manual must be done by a dedicated service center following a specific service/repair manual.
3. STOP Auger BEFORE performing maintenance and service per STOPPING AUGER in OPERATING INSTRUCTIONS section of this manual.

WARNING

- **DO NOT perform service and/or repair related functions with Auger mounted to 999 Series Display Stands.**
- **Stands are not designed and/or intended for hole digging and service functions.**
- **Such use can result in property damage and/or personal injury.**

4. Inspect for loose or broken parts. Inspect all fasteners, individual parts, operator controls and safety devices for proper function. Tighten fasteners as necessary. Replace any worn or damaged part or assembly.
5. Remove all loose accumulations, dirt, grease to prevent safety hazards, poor performance and reduced service life using safety type solvent.

DANGER

- Use safety type solvent.
- **DO NOT use thinner, benzene, or other volatile solvents that will attack rubber/plastic components when cleaning Auger.**
- Provide adequate ventilation.
- **DO NOT smoke while using cleaning solvents.**
- **DO NOT use solvents with engine running or if it is hot.**
- Allow ample time for engine to cool BEFORE using solvents.
- **An ignition source in close proximity to hot engine can be the source of an explosion, resulting in property damage and/or personal injury.**

6. Inspect engine throttle control and throttle cable assemblies are not damaged, bent, abraded or parts missing, are in correct operating position and allow for complete freedom of movement. DO NOT operate Auger with damaged engine throttle control arm and/or throttle cable assembly.
7. Inspect throttle control grip is free of moisture, pitch, oil or grease and is not cracked, damaged or worn. DO NOT operate Auger until such grip is repaired and/or replaced to prevent aggravated effects of "kickback and/or loss of operator control when digging.
8. Inspect operator handle and attach areas for signs of cracking, fatigue, deformation or damage. If cracking, fatigue, deformation or damage is present, replace. Keep handle clean and free of dirt, moisture, grease, oil and other, foreign material accumulations.

IMPORTANT: Keep external condition of operator handle and throttle control free of accumulation of moisture, dirt, pitch and other foreign substance that can provide a conductive pathway for energy to be transmitted. Throttle control should be maintained in clean, dry condition and free of all foreign materials.

9. Inspect centrifugal clutch assembly properly disengages at specified engine speed or slips during overload conditions.
10. Inspect engine muffler for wear or damage and replace as necessary to minimize fire hazard and hearing loss risk. If muffler is equipped with a spark arresting device, check for proper working condition. If not, replace with approved replacement from engine manufacturer.

IMPORTANT: It is owner(s) and/or operator(s) responsibility to provide and maintain a USDA approved, spark arresting muffler in an operating area specified by law. Check appropriate governing agencies for more specific information. Auger must not be operated if muffler is faulty or has been removed.

11. Inspect all safety and operation decals. If any decal becomes damaged and/or unreadable, replace.
12. Auger may utilize self-locking type hexagon nuts to minimize effects of vibration. If worn or damaged, replace.
13. Inspect auger bit for bent or damaged axle that will cause auger to "wobble" during use and can cause loss of machine control. Maximum allowable auger bit wobble is 0.25 inch (7 mm) total indicator runout (TIR). Auger bits with TIR in excess of this value must be removed from service and scrapped.
14. Inspect auger bit blade and screw bit for excessive wear, cracking, sharpness and missing parts. Replace as required to prevent undo wear to boring head and inverted cone configuration to auger flighting. The end result is substandard productivity and usually requires complete auger bit replacement. FIGURE 15. Auger bit service life can be greatly extended with constant auger bit wear part maintenance.

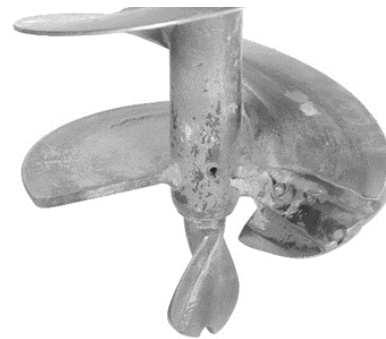

FIGURE 15

WARNING

- **DO NOT use auger bit with auger blade and screw worn past their specific service limits.**
- **Excessive wear to auger bit blade and screw bit will allow auger bit flighting to wear in a tapered or inverted cone configuration.**
- **A worn boring head may only be capable of digging a hole 60 to 75 percent of auger bit nominal diameter.**
- **Configuration will allow auger bit to "bind" in hole and substantially reduce operator control and productivity.**

DANGER

- **DO NOT operate auger bit which has bent or damaged axle with total indicator runout exceeding maximum allowable limit.**
- **Excessive auger bit wobble can reduce operator control, resulting in property damage and/or personal injury.**

15. Consult material supplied by engine manufacturer for specific information relative to proper operation, lubrication and storage requirements.

CHANGING AUGER TRANSMISSION GREASE

Tools Required:

- 1 each, 7/16 inch (12 mm) wrench
- 1 each, #2 Phillips head screwdriver
- 1 each, torque wrench, 120 inch pounds (13.5 N.m.) capacity with 7/16 inch (12 mm) socket
- 1 each, plastic hammer

Parts Required:

- 1 each, PN 240-0100PAK2 transmission gasket
- 1 each, PN 210-0720 grease packet or 8 ounces (224 g) of high temperature transmission or marine-grade, wheel bearing grease classified for extreme pressure (EP) applications. Fisk Brothers (Lubriplate brand) GR132 is an approved lubricant.

NOTE: Changing transmission lubricant will require a level working platform of sufficient size and appropriate height. As an alternative, the transmission driveshaft can be securely mounted in suitable bench vise.

1. Change transmission oil every 50 hours of operation, or more often as necessary, if Auger is operated in extremely dusty or dirty conditions.
2. STOP Auger per STOPPING AUGER in OPERATING INSTRUCTIONS section of this manual.
3. Drain fuel from fuel tank into a UL, CSA or UN marked, European ADR regulation approved fuel container. Wipe any excess spilled fuel and dispose of excess fuel and/or rags per international and local regulations.

! DANGER

- **DO NOT smoke near fuel tank.**
- **DO NOT fill fuel tank with engine running or if it is hot.**
- **Allow ample time between each refueling for engine to cool.**
- **An ignition source in close proximity to fuel tank can be the source of an explosion, resulting in property damage and/or personal injury.**
- **Consult material supplied by engine manufacturer for information relative to proper fueling procedures.**

4. Remove transmission assembly bolts. Use plastic hammer to split/ separate transmission cover and case. **DO NOT** damage alignment dowel pins.

NOTE: If journals of secondary pinion gear are difficult to remove from ball bearings, transmission cover and case will separate with greater difficulty. It may be necessary to provide a supplemental force to the pinion journals to assist the removal process. If difficult to remove, complete STEP 5 thru 6. If able to remove journals easily and separate cover and case, proceed to STEP 7.

5. Using Phillips screwdriver, remove screw, lock washer and flat washer from outside of transmission case and set aside. FIGURE 16
6. Insert a 1/4-20 UNC cap screw with a minimum 1 inch (25.4 mm) into location where screw was removed. Using wrench, turn capscrew in clockwise direction to apply thrust against pinion bearing journal until it clears pinion gear support bearing. Repeat process with transmission cover if necessary. FIGURE 16



FIGURE 16

7. Remove gasket plus, primary gear and pinion assembly.
8. Clean interior surfaces of transmission cover and case plus, pressure relief valve with safety type solvent.
9. Clean each gear with safety type solvent. Inspect teeth for excess wear, cracks or fatigue. Replace parts as necessary.

! DANGER

- **Use safety type solvent.**
- **DO NOT use thinner, benzene, or other volatile solvents that will attack rubber/plastic components when cleaning Auger.**
- **Provide adequate ventilation.**
- **DO NOT smoke while using cleaning solvents.**
- **DO NOT use solvents with engine running or if it is hot.**
- **Allow ample time for engine to cool BEFORE using solvents.**
- **An ignition source in close proximity to hot engine can be the source of an explosion, resulting in property damage and/or personal injury.**

10. Fill transmission cover and case with 8 ounces (224 g) of high temperature transmission grease containing an extreme pressure additive. If Fisk Brothers GR-132 lubricant is not available, marine-grade, wheel bearing grease classified for extreme pressure (EP) applications can be used in its place. Refer to FIGURE 17

IMPORTANT: DO NOT use standard lithium-based greases intended for common lubrication purposes. Such grease does not contain an extreme pressure additive for use with gears or for operating at higher temperatures encountered during hole digging process.

11. Reinstall primary gear and pinion assembly. Distribute grease equally around all gear teeth. Install new transmission gasket. FIGURE 17



FIGURE 17

12. Reinstall transmission cover to case, being careful to align transmission dowel pins during process.
13. Reinstall transmission assembly bolts with hexagon nuts placed on transmission cover side. Torque all bolts to 96 inch pounds (12 N.m.) in an "X" sequence.
14. Rotate driveshaft and check for excessive noise and/or binding. If excessive noise and/binding is evident, disassemble transmission and investigate for probable causes. Reassemble and retorque to specified amount. Recheck for excessive noise and/or binding.

MAGURA® THROTTLE CONTROL MAINTENANCE PROGRAM

For every 8 hours of actual operation and whenever throttle cable is replaced, the following maintenance program is to be followed:

1. Remove plastic cover to properly inspect internal components. If damaged or worn, replace. FIGURE 18



FIGURE 18

2. Inspect idler pulley. Normal use will produce a wear pattern into idler pulley by throttle cable. Maximum allowable groove wear depth created by cable is 0.045 inch (1.1 mm). Wear depth in excess of this limit requires idler pulley replacement.
3. Inspect throttle cable for excessive wear and fraying of area in direct contact with idler pulley. Abnormal wear or fraying requires replacement of throttle cable.
4. Inspect barrel end of throttle cable for proper retention. Properly retained barrel end will have no relative movement between it and inner cable. Any relative movement requires throttle cable replacement. FIGURE 19

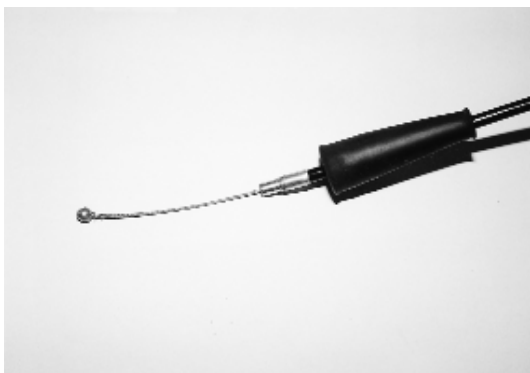

FIGURE 19

5. Inspect receptacle area of throttle control which retains barrel end of throttle cable. Properly fitted barrel fitting should have complete freedom of movement with no binding restrictions or excessive play due to wear. Barrel fitting which is binding within receptacle requires throttle cable replacement. Excessive receptacle wear requires specific component assembly replacement. FIGURE 20



FIGURE 20



CAUTION

- DO NOT operate Auger without rubber boot in proper location or in poor condition.
- Without boot assembly, foreign material can accumulate within throttle control assembly.
- Such an occurrence can restrict movement of internal components, reducing operator control of Auger and result in property damage and/or personal injury.

6. Apply appropriate preservative to rubber boot assembly to protect internal components from foreign material accumulations.
7. If regular throttle control inspection determines carburetor return spring does not properly return to engine cut-off position, remove throttle control grip tube from throttle control handle. Inspect tube and operator handle surface area for accumulation of foreign material, including dirt, moisture, etc. Remove any accumulation, clean as necessary. DO NOT apply external lubrication to this area during reassembly process.
8. Inspect throttle control grip proper attachment to throttle control assembly. Replace grip which fits loose or has become worn/damaged.

REPLACING WORN AUGER SCREW BIT

Application: All 1 inch diameter drive auger bits.



DANGER

- **Wear safety eyewear and other safety apparel appropriate for the job application and/or job site environment.**
- **Screw bit replacement process can create flying steel chips and/or other debris.**
- **Caution all onlookers regarding the possibility of and/or to remain clear of flying debris.**
- **Improper safety procedures can result in property damage and/or personal injury.**

Tools Required:

- 1 each, safety glasses
- 1 each, hammer (if required)
- 1 each, 1/4 inch diameter straight-type punch (if required)
- 2 each, 1/2 inch (12.7 mm) wrenches

Parts Required:

- 1 each, PN BR10636 Auger Screw Bit for 3 inch (76.2 mm) diameter auger bit
- 1 each, PN BR10637 Auger Screw Bit for 2 inch (50.8 mm) and 4 inch (101.6 mm) to 8 inch (203.2 mm) diameter auger bits.
- 1 each, PN 20051000 Roll Pin for 2 inch (50.8 mm) and 3 inch (76.2 mm) diameter auger bits if required.
- 1 each, PN 15051300 Bolt for 4 inch (101.6 mm) to 8 inch (203.2 mm) diameter auger bits, if required.
- 1 each, PN 52050000 Nut for 4 inch (101.6 mm) to 8 inch (203.2 mm) diameter auger bits, if required.

NOTE: Screw bit for 2 and 3 inch diameter auger bits functions as boring head. No other blade is used.

NOTE: Replacement of auger bit screw bit will require a level working platform of appropriate size and height.

1. Inspect auger screw bit for excess wear and/or damage. A worn screw bit with excess wear and/or damage will not allow auger bit to properly dig.
2. For 2 and 3 inch diameter auger bits, use hammer and straight-type punch to remove roll pin and screw bit.
3. For 4-inch diameter auger bit and above, use 1/2 inch (12.7 mm) wrenches to remove bolt and screw bit.
4. Insert replacement screw bit, align holes and reinstall applicable roll pin or bolt and nut with appropriate tools.
5. Return auger bit back to service.

REPLACING WORN AUGER BIT BLADE

Application: All 1 inch diameter drive connection, 4 inch diameter auger bits or larger.

DANGER

- Wear safety eyewear and other safety apparel appropriate for the job application and/or job site environment.
- Blade replacement process can create flying steel chips and/or other debris.
- Caution all onlookers regarding the possibility of and/or to remain clear of flying debris.
- Improper safety procedures can result in property damage and/or personal injury.

Tools Required:

- 1 each, safety glasses
- 2 each, 7/16 inch (12 mm) wrenches

Parts Required:

- 1 each, PN BR10631, 4 inch (101.6 mm) diameter auger bit blade
 - 1 each, PN BR10632, 6 inch (152.4 mm) diameter auger bit blade
 - 1 each, PN BR10633, 8 inch (203.2 mm) diameter auger bit blade
- Required Quantity: 15040600 1/4-20 x 3/4 inch bolt and 52040000 1/4-20 nut

All blades use 1/4 inch (7 mm) diameter capscrews and locknuts to retain blade to auger bit boring head. Each blade incorporates a minimum of two capscrews. Auger bits with only one capscrew visible and/or usable is worn beyond useful service life and must be discarded.

NOTE: Replacement of auger bit blade will require level working platform of appropriate size and height.

1. Using 7/16 inch (12 mm) wrenches, loosen capscrews and remove worn blade from auger bit plate. Remove any accumulated dirt from auger bit plate area. Install replacement blade with bevel of blade teeth and capscrew threads facing up toward auger bit hub. Tighten firmly with wrenches.

NOTE: Replacement blade will extend past outside diameter of auger bit plate for added component wear protection.

2. Return auger bit back to service.

12 SERVICE/REPAIR INSTRUCTIONS



The following information is intended for non-scheduled service/repair situations when specific issues arise affecting Auger performance. Information is for reference only and is not intended to be all inclusive.

1. Use factory approved replacement parts/accessories only for servicing/repair purposes.

WARNING

- Operating Auger utilizing components not meeting minimum operational standards can result in property damage and/or personal injury.

2. All service/repairs not described in this operator manual must be done by a dedicated service center following a specific service/repair manual.
3. STOP Auger BEFORE performing service and repair per STOPPING AUGER in OPERATING INSTRUCTIONS section of Operator's Manual.

WARNING

- DO NOT perform service and/or repair related functions with Auger mounted to 999 Series Display Stands.
- Stands are not designed and/or intended for these functions.
- Such use can result in property damage and/or personal injury.

4. All engine service/repairs should be done according to contents of engine manufacturer material.

PRESSURE RELIEF VALVE SERVICING

Pressure relief valve is located on transmission cover top surface to relieve excess pressure in transmission due to heat rise. If valve becomes plugged, the following problems can occur:

- a) Transmission grease can be forced out between bearings and driveshaft.
- b) Gasket separating transmission cover and case can push out, causing loss of transmission grease.

1. To minimize issues, clean pressure relief valve with safety type solvent when replacing centrifugal clutch rotor and shoe assembly or clutch drum and pinion assembly.

DANGER

- Use safety type solvent.
- DO NOT use thinner, benzene, or other volatile solvents that will attack rubber/plastic components when cleaning Auger.
- Provide adequate ventilation.
- DO NOT smoke while using cleaning solvents.
- DO NOT use solvents with engine running or if it is hot.
- Allow ample time for engine to cool BEFORE using solvents.
- An ignition source in close proximity to hot engine can be the source of an explosion, resulting in property damage and/or personal injury.

CENTRIFUGAL CLUTCH ROTOR/SHOE ASSEMBLY REMOVAL & INSTALLATION

The Auger utilizes an all metal centrifugal clutch rotor and shoe assembly that expands with engine RPM to engage clutch drum and transfer torque. The clutch rotor and shoe assembly is mounted to the engine crankshaft. Clutch assembly replacement symptoms include the following:

- a) Excessive clutch slippage and auger stalling at full, governed engine speed.
- b) Partial clutch engagement (and resulting auger bit rotation) at specified engine idle speed.

To replace clutch assembly, proceed as follows:

Tools Required:

- 1 each, 7/16 inch (12 mm) wrench
- 1 each, 17 mm socket with impact wrench
- 1 each, torque wrench, 120 inch pounds (13.4 N.m.) capacity and 17 mm socket
- 1 each. Container of Loctite 609 or equivalent

Parts Required:

- 1 each, PN 240-0100PAK2 transmission gasket (if required)
- 1 each, PN 242-0160 drum and pinion shaft assembly (if required)
- 1 each, PN 240-0170 rotor and shoe assembly







The transmission is designed for removal of the centrifugal clutch rotor and shoe assembly without disturbing transmission cover and case assemblies. Upon inspection, if centrifugal clutch drum and pinion shaft require replacement, the transmission cover and case will require further disassembly.

NOTE: Centrifugal clutch rotor/shoe assembly removal and installation will require a level working platform of sufficient size and appropriate height. As an alternative, the transmission output driveshaft can be securely mounted in suitable bench vise.

1. Drain fuel from fuel tank into a UL, CSA or UN marked, European ADR regulation approved fuel container and oil from engine crankcase. If re-use is not possible, disposal must be carried out according to international and local environmental standards.



DANGER

- **DO NOT** smoke near fuel tank.
- **DO NOT** fill fuel tank with engine running or if it is hot.
- **Allow ample time between each refueling for engine to cool.**
- **An ignition source in close proximity to fuel tank can be the source of an explosion, resulting in property damage and/or personal injury.**
- **Consult material supplied by engine manufacturer for information relative to proper fueling procedures.**

2. Using 7/16 inch (12 mm) wrench, remove four K-lock type nuts that retain engine to transmission. Remove engine from transmission and operator handle from engine leaving throttle cable connected to engine. Store operator handle in a position that does not damage throttle cable.
3. Position engine with rotor and shoe assembly facing up. Properly secure to prevent movement.
4. Using impact wrench and 17 mm socket, remove two capscrews retaining rotor and shoe assembly. **NOTE:** capscrew threads are righthanded. Remove rotor and shoe assembly from engine flywheel. FIGURE 21









FIGURE 21

5. Clean engine flywheel and clutch drum areas with safety type solvent.



DANGER









- **Use safety type solvent.**
- **DO NOT** use thinner, benzene, or other volatile solvents that will attack rubber/plastic components when cleaning Auger.
- **Provide adequate ventilation.**
- **DO NOT** smoke while using cleaning solvents.
- **DO NOT** use solvents with engine running or if it is hot.
- **Allow ample time for engine to cool BEFORE** using solvents.
- **An ignition source in close proximity to hot engine can be the source of an explosion, resulting in property damage and/or personal injury.**

6. Inspect engine flywheel, crankcase castings, mounting studs and clutch drum for cracks and other signs of visible damage. Any damaged component will require immediate replacement.
7. If clutch drum shows signs of severe wear and/or damage and requires replacement, refer to CENTRIFUGAL CLUTCH DRUM/PINION SHAFT REMOVAL AND INSTALLATION in SERVICE/REPAIR INSTRUCTIONS section of this manual. Severe wear is defined as:
 - a) Deep grooves cut into walls of drum measuring greater than 3.140 (79.76 mm) diameter.

- b) Deep, dark blue color that might indicate sustained operation at high temperatures while slipping. Extended and sustained operation can potentially weaken structural integrity of the brazed connection between drum and pinion shaft.

8. Clean and inspect hardware that retains rotor and shoe assembly to the engine flywheel. Replace any component showing cracks and other signs of visible damage that are present.
9. Apply Locktite 609 or equivalent to the shoulder bolt threads.
10. Locate replacement clutch rotor and shoe assembly plus, thrust washers on engine flywheel with direction arrow pointing in counterclockwise direction. This orientation properly maximizes the torque transmitting capabilities of the clutch. Refer to FIGURE 21



CAUTION

- Improper clutch and rotor shoe assembly orientation will result in increased slippage and reduced digging capacity with increased clutch wear.

11. Reinstall retaining shoulder bolts to 5.4-7.2 foot pounds (7.5-10 N.m.). When properly installed and torqued, shoulder bolts should not thrust directly against washers, but apply a direct force against the clutch shoes. If force is applied against the washers, it will restrict proper movement of the clutch shoes.



CAUTION

- Improper shoulder bolt clearance will limit proper movement of clutch shoes and overall operation.
- Such an occurrence can result in property damage and/or personal injury.

12. Reinstall operator handle to engine and engine to transmission with correct orientation to the operator handle. Throttle control of operator handle goes on same side of engine with ON/OFF ignition switch and same side of transmission cover that pressure relief valve is located.



WARNING

- **Improper engine mounting orientation to transmission can reduce machine control during hole digging process.**
- **Such an occurrence can result in property damage and/or personal injury.**

13. Using 7/16 inch (12 mm) wrench, reinstall and tighten the four K-lock nuts. Tighten nuts to an approximate 90 inch pound (10 N.m.) value. This will place the nut flush with end of engine mounting stud.

NOTE: There is not adequate space to allow use of a conventional torque wrench.

14. Rotate driveshaft and check for excessive noise and/or binding. If excessive noise and/or binding is evident, disassemble engine from transmission and investigate for probable causes. Reassemble and retorque to the specified values. Recheck again for excessive noise and/or binding.
15. Refill engine fuel tank and crankcase with appropriate fluids as required.

CENTRIFUGAL CLUTCH DRUM/PINIONSHAFT ASSEMBLY REMOVAL & INSTALLATION

Tools Required:

- 2 each, 7/16 inch (12 mm) wrenches
- 1 each, plastic hammer
- 1 each, #2 Phillips head screwdriver
- 1 each, snap ring pliers
- 1 each, torque wrench, 120 inch pounds (13.5 n.m.) capacity

Parts Required:

- 1 each, PN 240-0100PAK2 transmission gasket
- 1 each, PN 242-0160 drum and pinion shaft assembly
- 1 each, PN 5100-088 snap ring
- 1 each, container of thread anti-seize

NOTE: Centrifugal clutch drum/pinion shaft assembly removal and installation will require a level working platform of sufficient size and appropriate height. As an alternative, the transmission output driveshaft can be securely mounted in suitable bench vise.

1. Drain fuel from fuel tank into a UL, CSA or UN marked, European ADR regulation approved fuel container and oil from engine crankcase. If re-use is not possible, disposal must be carried out according to international and local environmental standards.

⚠ DANGER



- **DO NOT smoke near fuel tank.**
- **DO NOT fill fuel tank with engine running or if it is hot.**
- **Allow ample time between each refueling for engine to cool.**
- **An ignition source in close proximity to fuel tank can be the source of an explosion, resulting in property damage and/or personal injury.**
- **Consult material supplied by engine manufacturer for information relative to proper fueling procedures.**

2. Using 7/16 inch (12 mm) wrench, remove four K-lock type nuts that retain engine to transmission. Remove engine from transmission and operator handle from engine leaving throttle cable connected to engine. Store operator handle in a position that does not damage throttle cable.
3. Remove transmission assembly bolts. Use plastic hammer to split/separate transmission cover and case. **DO NOT** damage alignment dowel pins.

NOTE: If bearing journals of secondary pinion gear are difficult to remove from ball bearings, transmission cover and case will separate with greater difficulty. It may be necessary to provide a supplemental force to the pinion journals to assist the removal process. If difficult to remove, complete STEP 4 thru 5. If able to remove journals easily and separate cover and case, proceed to STEP 6.

4. Using Phillips screwdriver, remove screw, lock washer and flat washer from outside of transmission cover and set aside. FIGURE 22
5. Insert a 1/4-20 UNC cap screw with a minimum 1 inch (25.4 mm) into location where screw was removed. Using wrench, turn capscrew in clockwise direction to apply thrust against pinion bearing journal until it clears pinion gear support bearing. FIGURE 22



FIGURE 22

6. Using snap ring pliers, remove snap ring retaining clutch drum/shaft assembly to transmission cover. FIGURE 23



FIGURE 23

7. Inspect support bearings for excessive wear. Replace as necessary.
8. Install replacement drum/shaft assembly in transmission cover. Determine drum fits tight against the bearings.
9. Reinstall snap ring.
10. If it is determined transmission grease should be replaced, refer to CHANGING AUGER TRANSMISSION LUBRICANT in MAINTENANCE INSTRUCTIONS section of this manual.
11. Remove old gasket and install new one.
12. Reinstall transmission cover to case, being careful to align transmission dowel pins during process.
13. Reinstall transmission assembly bolts with hexagon nuts placed on transmission cover side. Torque all bolts to 96 inch pounds (12 N.m.) in an "X" sequence.
14. Rotate driveshaft and check for excessive noise and/or binding. If excessive noise and/or binding is evident, disassemble transmission and investigate for probable causes. Reassemble and retorque to specified amount. Recheck for excessive noise and/or binding.
15. Reinstall operator handle to engine and engine to transmission with correct orientation to the operator handle. Throttle control of operator handle locates on same side of engine with ON/OFF ignition switch and same side of transmission cover that pressure relief valve is located.



WARNING

- **Improper engine mounting orientation to transmission can reduce machine control during hole digging process.**
- **Such an occurrence can result in property damage and/or personal injury.**

16. Using 7/16 inch (12 mm) wrench, reinstall and tighten the four K-lock nuts. Tighten nuts to an approximate 90 inch pound (10 N.m.) value.

NOTE: There is not adequate space to allow use of a conventional torque wrench.

17. Rotate driveshaft and check for excessive noise and/or binding. If excessive noise and/or binding is evident, disassemble engine from transmission and investigate for probable causes. Reassemble and retorque to the specified values. Recheck again for excessive noise and/or binding.
18. Refill engine fuel tank and crankcase with appropriate fluids as required.

ENGINE SERVICE

Consult applicable material supplied by engine manufacturer for specific service and maintenance information regarding:

1. muffler
2. spark plug
3. air filter
4. carburetor adjustment
5. maintenance schedule
6. engine oil change
7. troubleshooting
8. short and long term storage

Keep this information stored with Operator Manual for Auger so it will always be available for use when engine requires service or maintenance.

Under Title 13 of the California Code of Regulations, the California Air Resource Board (CARB) has identified several important engine service related subjects. The material supplied by specific engine manufacturer will include the following:

1. statement of compliance
2. engine oil recommendations
3. engine fuel recommendations
4. maintenance information
5. other information as required by (CARB)
6. emission component warranty statement

If you have any question regarding emission components, warranty rights and responsibilities for a specific engine used on Auger, contact Customer Service Department for specific information. There is no charge for this service.

13 TROUBLESHOOTING

NOTE: If troubleshooting information does not correct situation, all maintenance/repairs not described in this operator manual must be done by a dedicated service center following a specific service/repair manual.

ENGINE WILL NOT START

Possible Cause	Correction
Fuel valve in off position.	Turn fuel valve to on position.
Ignition cut-off switch (if equipped) improperly adjusted.	Adjust throttle cable.
Incorrect carburetor adjustment.	See engine manufacturer supplied information.
Ignition wire to spark plug loose or disconnected.	Reconnect.
Fuel supply exhausted.	Refill fuel tank.

ENGINE LOSES POWER

Possible Cause	Correction
Incorrect carburetor adjustment.	See engine manufacturer supplied information.
Water in fuel supply.	Drain and replace fuel.
Plugged engine exhaust ports.	See engine manufacturer supplied information.
Dirty spark plug.	See engine manufacturer supplied information.
Incorrect throttle control/cable adjustment.	See MAINTENANCE INSTRUCTIONS this manual.
Gasoline tank breather vent closed (if so equipped).	Open vent.
Dirty air filter.	See engine manufacturer supplied information.

ENGINE OVERHEATS

Possible Cause	Correction
Incorrect carburetor adjustment.	See engine manufacturer supplied information.
Cooling fins clogged with debris.	Remove engine blower housing and clean cooling fins.

AUGER LACKS POWER

Possible Cause	Correction
Incorrect transmission lubricant.	See CHANGING AUGER TRANSMISSION LUBRICANT in MAINTENANCE INSTRUCTIONS this manual.
Centrifugal clutch assembly worn.	Replace.
Incorrect throttle control/cable adjustment.	See MAINTENANCE INSTRUCTIONS this manual.

AUGER BIT ROTATES AT IDLE SPEED

Possible Cause	Correction
Incorrect throttle control/cable adjustment does not permit proper engine idle speed.	See MAINTENANCE INSTRUCTIONS this manual.
Centrifugal clutch worn.	Replace.
Incorrect engine idle speed.	See MAINTENANCE INSTRUCTIONS this manual.

14 STORAGE

TEMPORARY STORAGE (On Job Site)

Auger can be temporarily stored on job site by one of three acceptable methods. Method chosen by operator is based on personal preference and/or job site conditions.

1. In all three storage methods, STOP Auger per STOPPING AUGER in OPERATING INSTRUCTIONS section of this manual.

- a. Dig shallow hole and leave Auger connected to auger bit. FIGURE 24



FIGURE 24

- b. Disconnect Auger from auger bit and/or auger bit extension and store in level configuration. FIGURE 25



FIGURE 25

- c. Store Auger connected only to lead auger bit with engine spark plug facing upward to minimize potential for crankcase oil entering combustion chamber and causing hydraulic lock up. FIGURE 26

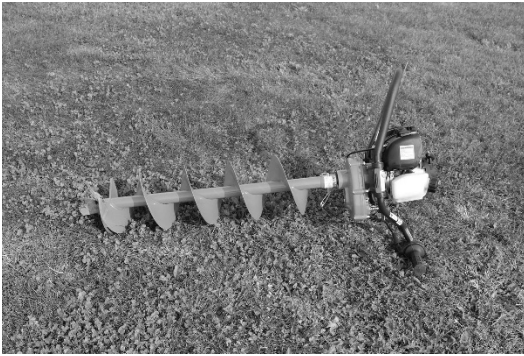



FIGURE 26

2. Protect operator handle from external sources of damage. DO NOT allow handle to contact auger bits, shovels, or other sharp/abrasive objects during transit whether stacked or thrown against handles. DO NOT drag Auger with handle or throttle grip contacting ground. Damage can result.

 **WARNING**

- DO NOT drop or impact Auger against ground.
- Action can damage twist grip throttle control, engine and result in property damage and/or personal injury.

 **DANGER**

- DO NOT store Auger with engine operating.
- Improper storage methods can result in property damage and/or personal injury.

LONG TERM STORAGE







Procedure for Auger long term storage will protect against effects of corrosion and damage. If Auger is not to be operated for a period of 30 days or more, proceed to store as follows:

1. STOP Auger per STOPPING AUGER in OPERATING INSTRUCTIONS section of this manual.

 **DANGER**

- Improper storage methods can result in property damage and/or personal injury.

2. Disconnect auger bit from Auger.
3. Follow procedure as outlined in material supplied by engine manufacturer detailing long term storage of engine.
4. Clean all accumulated dirt and grease from Auger utilizing safety type solvent. Provide adequate ventilation and observe all applicable safety precautions for solvent.

 **DANGER**      

- Use safety type solvent.
- DO NOT use thinner, benzene, or other volatile solvents that will attack rubber/plastic components when cleaning Auger.
- Provide adequate ventilation.
- DO NOT smoke while using cleaning solvents.
- DO NOT use solvents with engine running or if it is hot.
- Allow ample time for engine to cool BEFORE using solvents.
- An ignition source in close proximity to hot engine can be the source of an explosion, resulting in property damage and/or personal injury.

5. Inspect all visible parts for wear, breakage or damage. Replace any part required to make necessary repair with factory approved parts only.

6. Apply light coat of protective grease to transmission driveshaft to prevent formation of rust.
7. Store Auger with operator handle level with ground to prevent transmission oil draining from breather vent and damaging surrounding environment and to minimize potential for crankcase oil entering combustion chamber and creating hydraulic lock up.
8. DO NOT allow handle to come in contact with auger bits, shovels, or other sharp and abrasive objects during storage to prevent damage.
9. Store Auger inside. If Auger must be stored outside, protect it and each auger bit with a suitable covering.

15 END OF LIFECYCLE



If the machine comes to the end of its lifecycle, destruction of the machine must be conducted according to international and local environmental regulations.



20195 South Diamond Lake Road, Suite 100 • Rogers, MN 55374
Toll-Free: 800-350-8739 • Website: braveproducts.com • Email: sales@braveproducts.com

Dear Valued Customer:

The Brave product you just purchased is built with the finest material and craftsmanship. Use this product properly and enjoy the benefits from its high performance. By purchasing a Brave product, you show a desire for quality and durability. Like all mechanical equipment this unit requires a due amount of care. Treat this unit like the high-quality piece of machinery it is. Neglect and improper handling may impair its performance.

Thoroughly read the instructions and understand the operation before using your product. Always contact Brave Product Support at 1-800-350-8739 prior to having any service or warranty work performed, as some services performed by parties other than Brave approved service centers may void this warranty. This limited warranty is in lieu of any other warranty expressed or implied, written or oral and Brave assumes no other responsibility or liability outside that expressed within this limited warranty.

Limited Warranty for Brave and Brave Pro Augers:

BRPA180H
BRP240HHD

BRA250H
BRPA265H
BRPA270H
BRP330HHD
BRP343HHD

BRPA325H

	Consumer Warranty Period	Commercial Warranty Period
Weldments	2 years from date of purchase by user	2 year from date of purchase by user
Gear Case	2 years from date of purchase by user	1 year from date of purchase by user
Wear Parts	In addition to the normal warranty, Brave shall warrant some normal wear items from defects in material or workmanship for a period of 30 days from the date of purchase by user. Normal wear items covered under this warranty are limited to: High impact wear related components such as V-belts, flails, flail rods and flail drums. High abrasion wear related parts such as augers, auger fighting, boring heads, multi-accessory attachments, tungsten carbide inserts and flexible ducts. Engine throttle control cable assemblies and related control devices. Centrifugal clutch components such as shoes, springs drum and rotor assembly. Routine maintenance items such as lubricants, clutch adjustments, tune ups are not covered under warranty.	
Engines, Motors, Pumps and Controls	The warranty of these main components and engine is covered under the terms and conditions as outlined by the component and engine manufactures warranty contained herein and is the sole responsibility of the component and engine manufacturer. Normal engine maintenance such as spark plugs, oil changes, air filters, adjustments, fuel system cleaning and obstruction due to build up is not covered by this Brave limited warranty.	

“Consumer use” means personal residential household use by a consumer. “Commercial use” means all other uses, including, but not limited to, use for commercial, income producing or rental purposes or when purchased by a business.

This limited warranty applies to the original purchaser of the equipment (verification of purchase, in the form of a receipt, is the responsibility of the buyer), is non-transferable, and covers parts and labor. Parts will be replaced or repaired at no charge, except when the equipment has failed due to lack of proper maintenance. If a part is no longer available, the part may be replaced with a similar part of equal function. Any misuse, abuse, alteration or improper installation or operations will void warranty. Determining whether a part is to be replaced or repaired is the sole decision of Brave. Brave will not provide for replacement of complete products due to defective parts. Any costs incurred due to replacement or repair of items outside of a Brave approved facility is the responsibility of the buyer and not covered under warranty. Transportation costs to and from service center and/or service calls are the responsibility of the customer.

This limited warranty specifically excludes the following: failure of parts due to damage caused by accident, fire, flood, windstorm, acts of God, applications not approved by Brave in writing, corrosion caused by chemicals, use of replacement parts which do not conform to manufacturer’s specifications, damage related to rodent and/or insect infestation and damage caused by vandalism. Additional exclusions: loss of running time, inconvenience, loss of income, or loss of use, including any implied warranty of merchantability of fitness for a specific use. Also, outdoor power equipment needs periodic parts and service to perform well, and this limited warranty does not cover instances when normal use has exhausted the life of a component or the engine.

This limited warranty does not cover any personal injury or damage to surrounding property caused by failure of any part, misuse or inability to use the product. Alteration of the product, including safety features, shall void this limited warranty.

Repair or replacement of parts does not extend the warranty period. This limited warranty gives you specific legal rights. You may also have other rights that vary by state. Please have model number, item number and serial number on hand prior to making a warranty claim or inquiry.

For products purchased on or after February 1, 2015

Rev. 10/2020



**Brave
Product Registration Form**

YOUR INFORMATION

Full Name:

Last First M.I.

Address:

Street Address Apartment/Unit #

City State ZIP Code

Home Phone:

Alternate Phone: _____

Email

PURCHASED FROM

Company:

Address:

Street Address Apartment/Unit #

City State ZIP Code

MODEL INFORMATION

Purchase Date

Application Type

Homeowner Commercial Rental

Model (i.e. BRP240HHD)

Serial # (i.e. 123456)

Signature

Register your product online at www.braveproducts.com

*THIS PAGE INTENTIONALLY
LEFT BLANK*

*Replacement Parts Diagram
BRPA180H Auger
Equipped With Honda GX35 Engine*

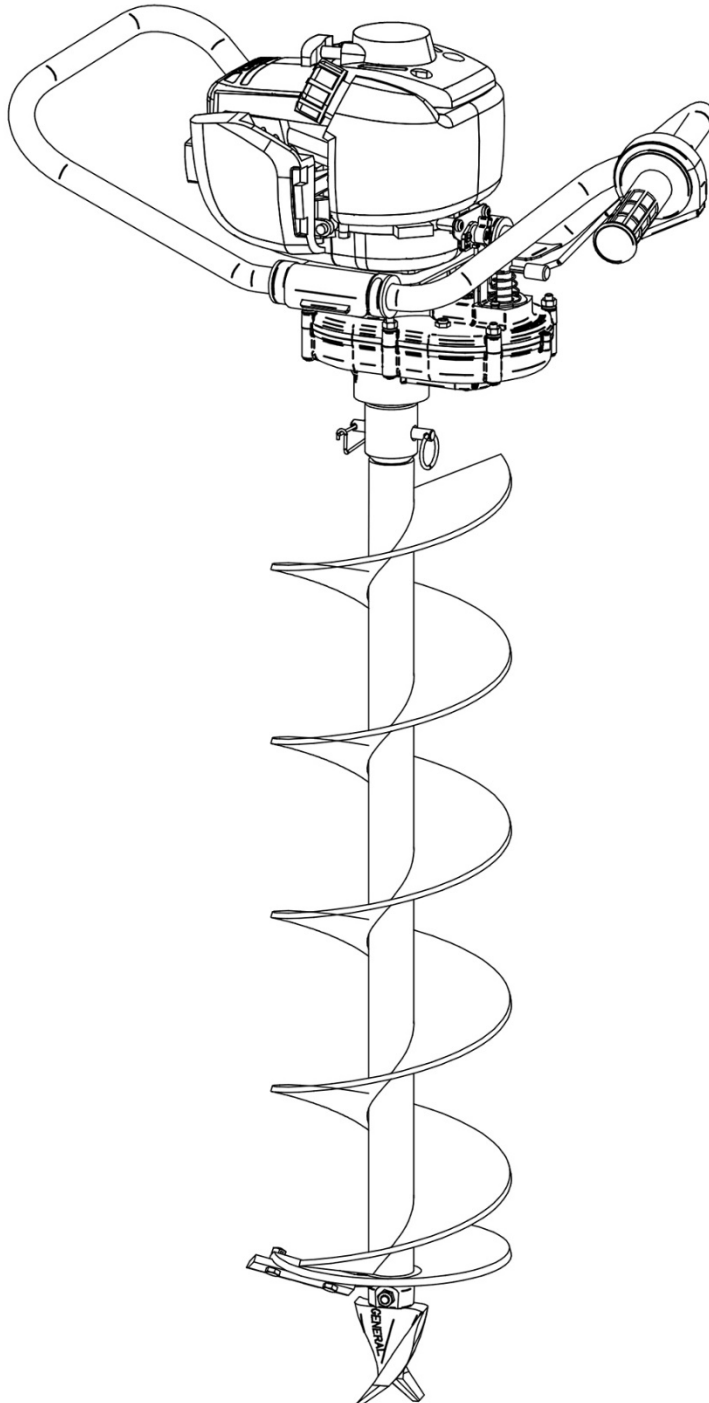

*Replacement Parts Diagram
Transmission Cover Assembly
BRPA180H Auger
[Beginning with Serial Number 174809]*

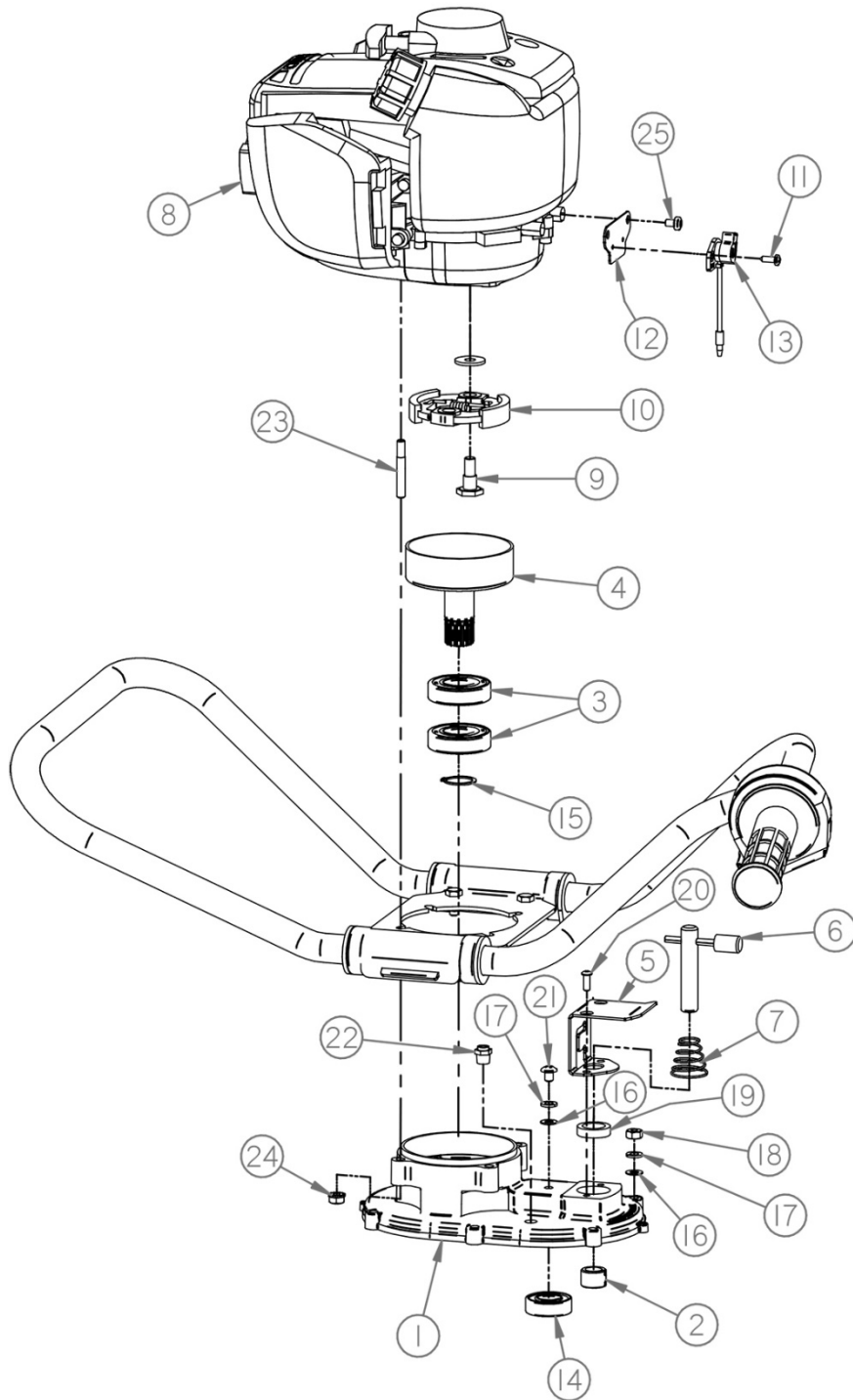

*Replacement Parts Diagram
Transmission Cover Assembly
BRPA180H Auger
[Beginning with Serial Number 174809]*

Reference Number	Part Number	Description	Quantity
1	242-0130ABR	Assembly, Cover, Transmission, (Includes Ref. 2, 3 & 14)	1
2	235-0140	Bushing, Spring-Type	1
3	FCS16-0331	Bearing, Support	2
4	242-0160	Drum, Clutch	1
5	235-0230	Plate, Pin, Lock	1
6	235-0220	Assembly, Pin, Lock	1
7	235-0110	Spring, Pin, Lock	1
8	GX35NTT3-BLK	Engine, Honda, GX35	1
9	240-0180	Screw, Cap, Retaining, Clutch	2
10	240-0170	Assembly, Rotor/Shoe, Clutch	1
11	240H-0340	Screw, Phillips, #8-12, Z	2
12	240H-0360	Bracket, Switch, ZY	1
13	240H-0350PAK2	Pak2, Switch, Engine, On/Off	1
14	99502H	Bearing, Ball	1
15	5100-088	Ring, Snap, External	1
16	AN-960-416L	Washer, Flat, 1/4, ZY	7
17	16040000	Washer, Lock, 1/4, ZY	7
18	18040000	Nut, Hex, 1/4-20, ZY	6
19	471442	Seal, Oil	1
20	55030400	BHSCS, #10-24 X 1/2, ZY	2
21	37040200	PHMS, 1/4-20 X 5/16, ZY	1
22	5677	Valve, Relief	1
23	240-0200	Stud, Mounting, M6 X 1/4-28	4
24	12040001	Nut, Hex, K-Lock, 1/4-28, ZY	4
25	90050-ZE1-000	PHST, M5 X 8, Z	2

*Replacement Parts Diagram
Transmission Case Assembly
BRPA180H Auger
[Beginning with Serial Number 174809]*

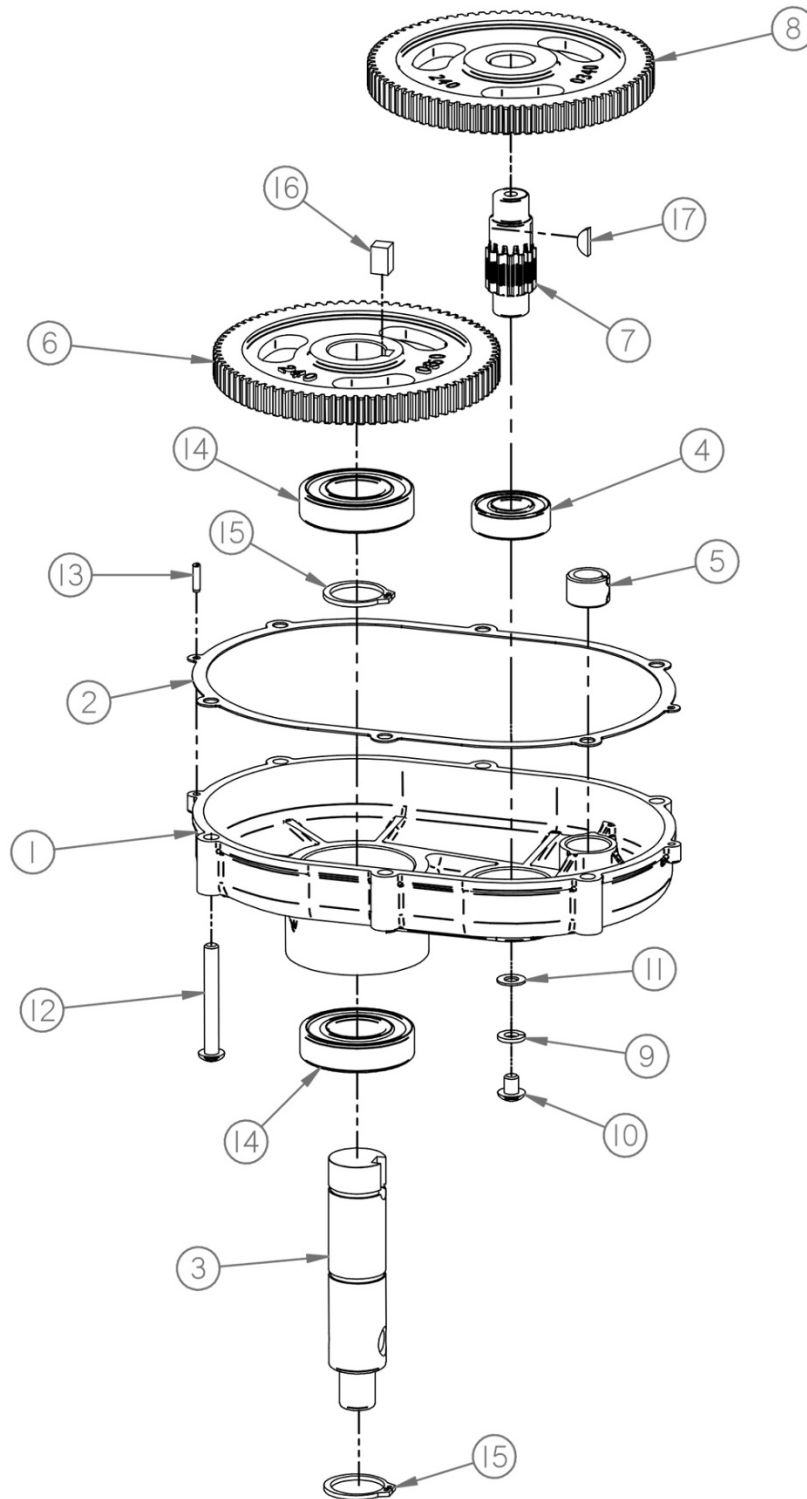

*Replacement Parts Diagram
Transmission Case Assembly
BRPA180H Auger
[Beginning with Serial Number 174809]*

Reference Number	Part Number	Description	Quantity
1	242-0120ABR	Assembly, Case, Transmission, (Includes Ref. 4, 5 & 14)	1
2	240-0100PAK2	Pak2, Gasket, Transmission	1
3	242-0330	Shaft, Drive, 1RD	1
4	99502H	Bearing, Ball	1
5	235-0140	Bushing, Spring-Type	1
6	240-0350	Gear, Secondary	1
7	210-0310	Gear, Pinion, Secondary	1
8	240-0340	Gear, Primary	1
9	16040000	Washer, Lock, 1/4, ZY	1
10	37040200	PHMS, 1/4-20 X 5/16, ZY	1
11	AN-960-416L	Washer, Flat, 1/4, ZY	1
12	34041600	Phrhms, 1/4-20 X 2, ZY	6
13	51020400	Pin, Dowl, 1/8 X 1/2	2
14	99R16	Bearing, Ball	2
15	5160-98	Ring, Snap	2
16	63050400	Key, Drive, Square, 5/16 X 1/2	1
17	3	Key, Woodruff, Alloy	1

*Replacement Parts Diagram
Operator Handle Assembly
BRPA180H Auger
[Used With Serial Number 174809 Thru 179766]*

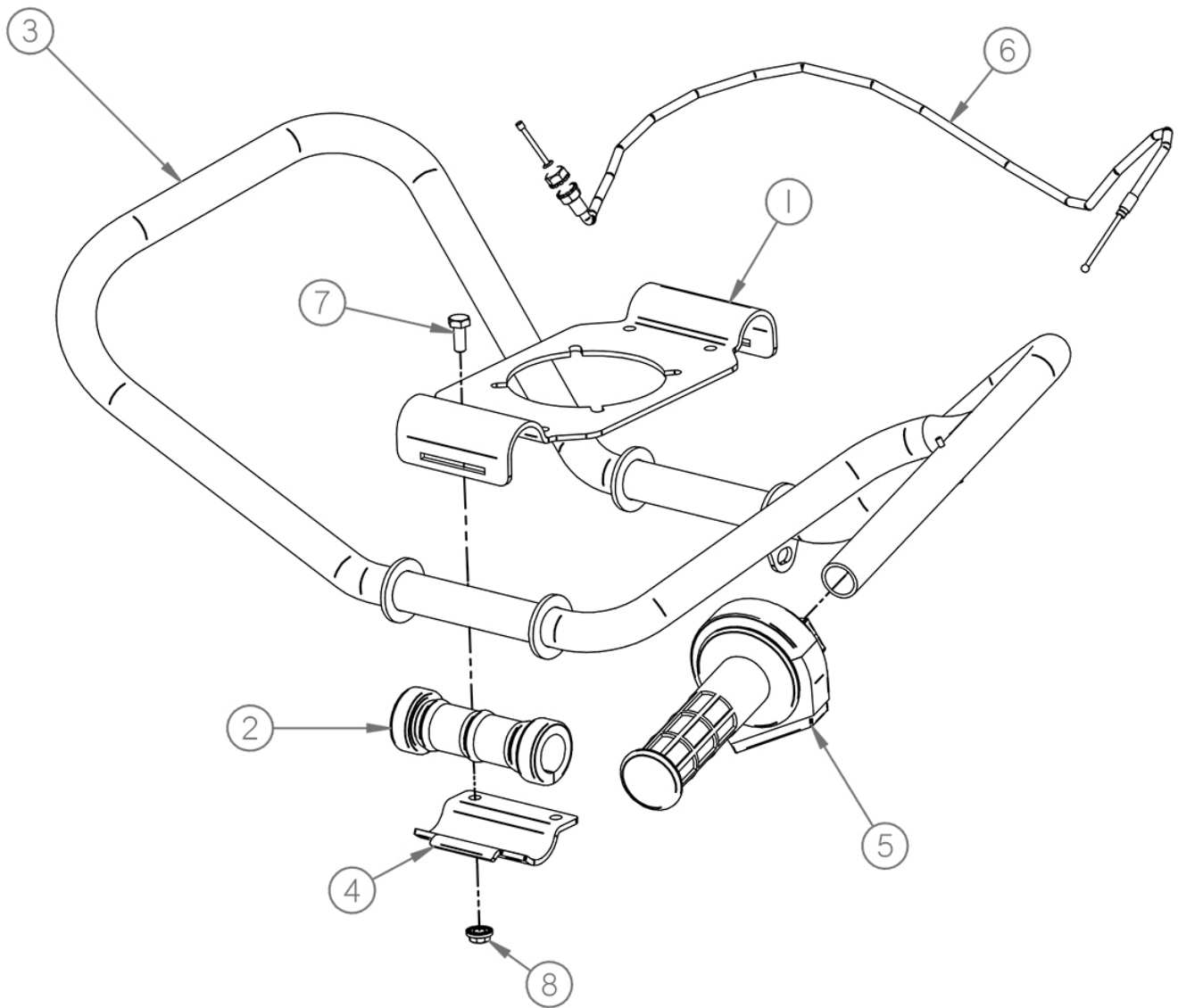

*Replacement Parts Diagram
Operator Handle Assembly
BRPA180H Auger
[Used With Serial Number 174809 Thru 179766]*

Reference Number	Part Number	Description	Quantity
1	242-0050	Bracket, Handle	1
2	242-0070	Bushing, Isolator, Handle	2
3	242-0090	Weldment, Handle, Operator	1
4	242-0060	Clamp, Handle	2
5	310-0030	Assembly, Control, Throttle	1
6	240H-0080PAK2	Pak2, Cable, Throttle	1
7	15040500	HHCS, 1/4-20 X 5/8, ZY	4
8	86040000	Nut, Hex, Flange, 1/4-20, ZY	4

*Replacement Parts Diagram
Operator Handle Assembly
BRPA180H Auger
[Beginning with Serial Number 179767]*

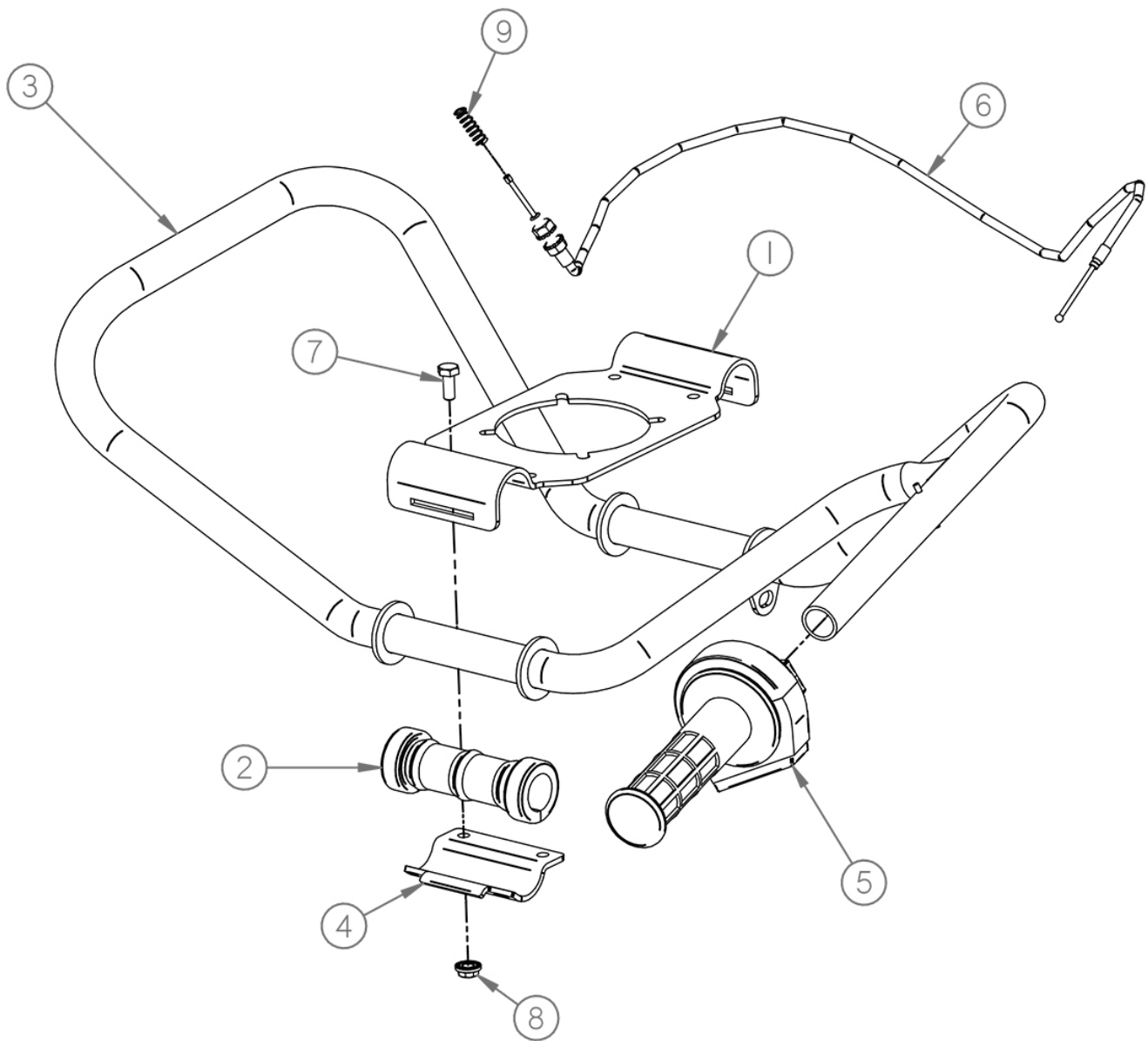

*Replacement Parts Diagram
 Operator Handle Assembly
 BRPA180H Auger
 [Beginning with Serial Number 179767]*

Reference Number	Part Number	Description	Quantity
1	242-0050	Bracket, Handle	1
2	242-0070	Bushing, Isolator, Handle	2
3	242-0090	Weldment, Handle, Operator	1
4	242-0060	Clamp, Handle	2
5	310-0030	Assembly, Control, Throttle	1
6	240H-0080PAK2	Pak2, Cable, Throttle, (Includes Ref. 9)	1
7	15040500	HHCS, 1/4-20 X 5/8, ZY	4
8	86040000	Nut, Hex, Flange, 1/4-20, ZY	4
9	242-0210	Spring, Return, Throttle, (Compatible With All BRP240HHD & BRPA180H Models)	1

*Replacement Parts Diagram
PN: 310-0030 Throttle Control Assembly
For Use With
BRPA180H Auger*

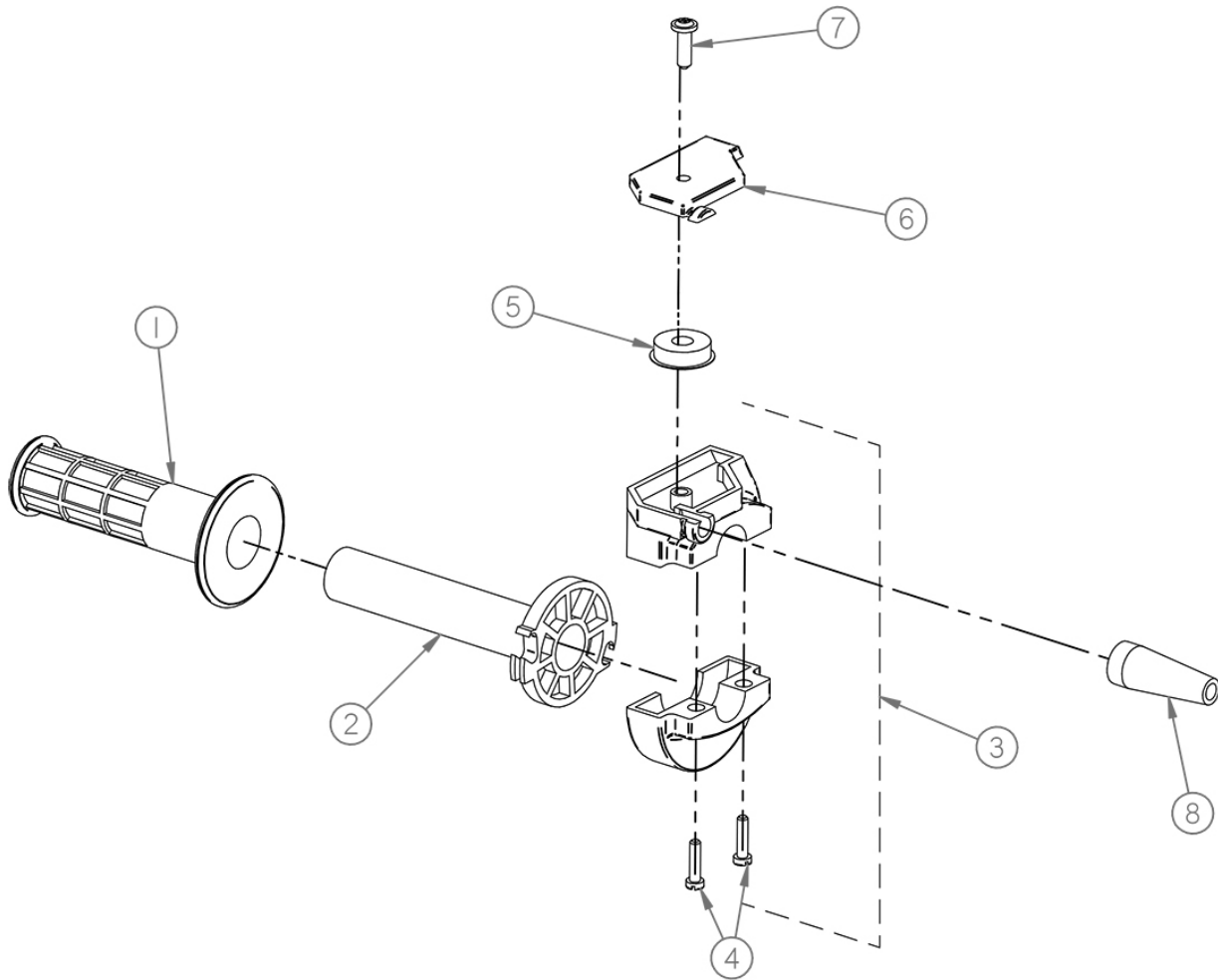

Reference Number	Part Number	Description	Quantity
1	310-0020-030	Grip, Throttle	1
2	310-0030-020-A	Tube, Throttle, W/Grip, (Includes Reference 1)	1
3	310-0030-010-A	Assembly, Body, W/Screws, (Includes Reference 4)	1
4	310-0030-040	Screw, Cheesehead, M5-.8 X 20	2
5	310-0030-070	Sheave, Roller	1
6	310-0030-060	Cover, Top	1
7	310-0030-050	Screw, Self-Tapping	1
8	310-0020-080	Boot, Rubber	1

Replacement Parts Diagram Machine Decals BRPA180H Auger [Beginning with Serial Number 174809]

BRAVE
CUSTOMER SERVICE INFORMATION
Avoid fire. Use the product properly. Do not use for any other purpose.
For technical or operation assistance for this product, first contact your
retailer. If the product was used, contact the dealer from which it
was rented. For further assistance, please contact the Brave Customer
Service Department. There is no charge for normal customer service advice
provided by Brave.

SG24-5072BR
DECAL, ASSISTANCE

WARNING
This product can expose you to chemicals
including gasoline, kerosene, oil, silica dusts and
aerosols which are known to the State of California
to cause cancer and/or Carbon Monoxide.
If gasoline engine powered, which is known to
cause birth defects or other reproductive harm.
For more information, visit www.P105Warnings.ca.gov.

GECD-5060
DECAL, WARNING, PROP 65

*ON BACK SIDE OF ENGINE

DANGER
CARBON MONOXIDE FUMES
PRODUCED BY THE ENGINE
CAN KILL. DO NOT USE
THIS MACHINE INDOORS OR
IN SHELTERED AREAS.

240-5090
DECAL, DANGER

*ON BACK SIDE OF
ENGINE

CHECK OIL LEVEL
ENGINE OIL
CAPACITY: 3.2 qt
(100mL)
OIL FILLER
CAP/FITTING
CHECK ENGINE
OIL LEVEL AS
SHOWN. SEE
10W-30 API SJ
OR LATER

240H-5010
DECAL, LEVEL, OIL

Earth Auger
BRAVE PRO
BRPA180H
POWERED BY HONDA

ZDBRPA180H
DECAL, ZDBRPA180H

READ BEFORE STARTING
PROPER OPERATOR POSITION REQUIRES
THE ENGINE TO BE STARTED WITH YOUR
LEFT HAND. CONSULT OPERATOR MANUAL
FOR ADDITIONAL INFORMATION.

240-5020
DECAL, STARTING

CAUTION HOT

210-5041
DECAL, MUFFLER HOT

THIS MACHINE UTILIZES A
4 STROKE ENGINE. DO
NOT MIX OIL WITH
GASOLINE. CHECK
CRANKCASE OIL LEVEL AS
RECOMMENDED IN THE
OPERATOR MANUAL.

240-5030
DECAL, 4 STROKE

CAUTION
EYE AND EAR
PROTECTION
REQUIRED

SP8-5041
DECAL, CAUTION, EYE/EAR

CAUTION
AVOID INJURY
READ AND UNDERSTAND
OPERATOR MANUAL BEFORE
OPERATING THIS PRODUCT.
DETERMINE YOU ARE OF
PROPER PHYSICAL BUILDING
AND CONDITION TO OPERATE
THIS MACHINE.

210-5021
DECAL, CAUTION, AVOID
INJURY

Auger-LOK Procedure

- Stop engine
- Rotate, drop and lock Auger-LOK pin to fully engage transmission gear.
- Rotate Hoop Digger counter-clockwise by hand until auger has been freed.
- Rotate, lift and lock Auger-LOK pin to fully disengage transmission gear.
- Confirm auger is free of obstructions before resuming to dig.

235-5020
DECAL, LOCK, AUGER

**MACHINE WEIGHT
LESS AUGER
20 LBS
(9 Kg)**

240-5080
DECAL, WEIGHT

*ON TRANSMISSION LOCK
PLATE

811
Know what's below.
Call before you dig.

240-5100
DECAL, 811

Replacement Parts Diagram 2 Thru 8 Inch Diameter Auger Bits 1 Inch Round Drive Connection For Use With BRPA180H Auger

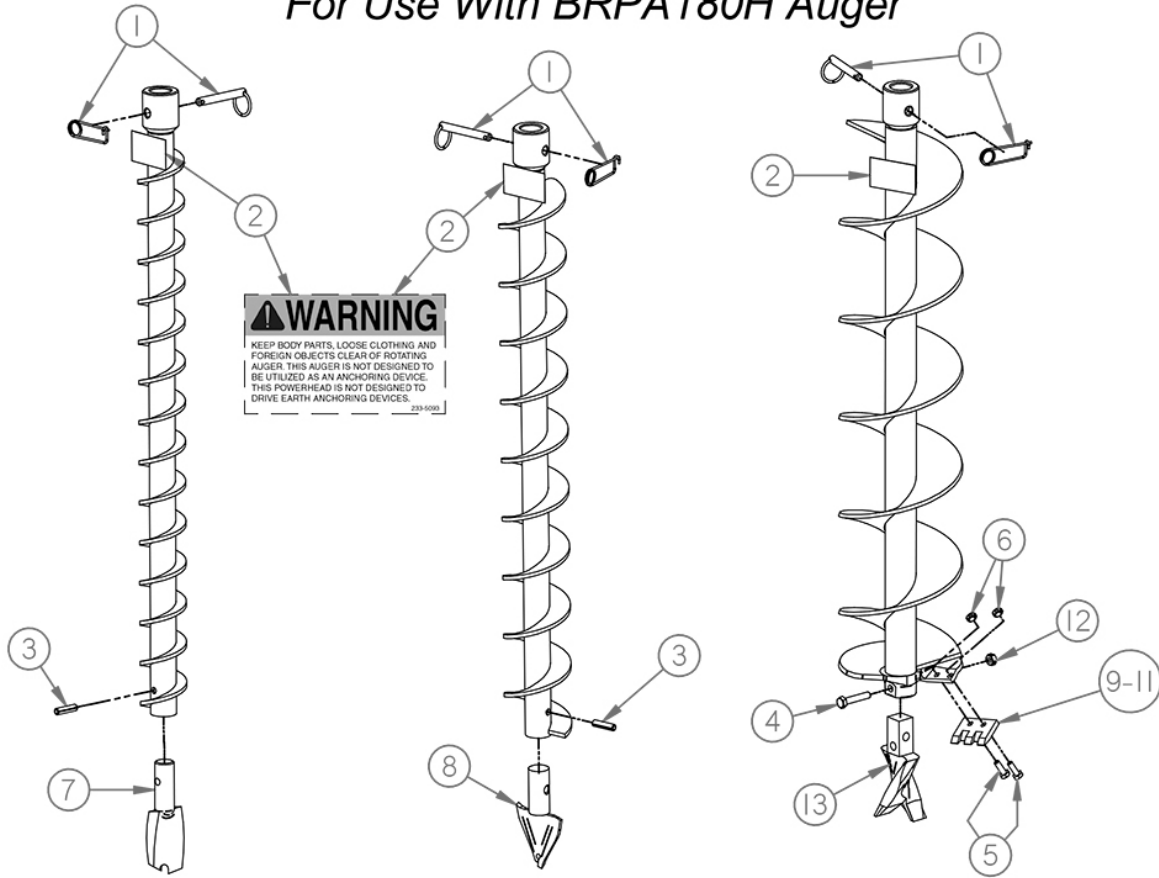

BR10639, 2 Inch Diameter Auger Bit

BR10640, 3 Inch Diameter Auger Bit

BR10641, 4 Inch Diameter Auger Bit
BR10642, 6 Inch Diameter Auger Bit
BR10643, 8 Inch Diameter Auger Bit

Reference Number	Part Number	Description	Application	Quantity
1	BR10628	Auger Pin (3 Pack)	All Auger Bits	1
2	233-5093	Decal, Caution, Clear Rotating	All Auger Bits	1
3	20051000	Pin, Roll, 5/16 X 1-1/4	BR10639, BR10640	1
4	15051300	HHCS, 5/16-18 X 1-5/8, ZY	BR10641 Thru BR10643	1
5	15040600	HHCS, 1/4-20 X 3/4, ZY	BR10641 Thru BR10643	2
6	52040000	Nut, Lock, 2-Way, 1/4-20, ZY	BR10641 Thru BR10643	2
7	BR10637	Auger Screw Bit, BR10639 Only. (3 Pack)	BR10639	1
8	BR10636	Auger Screw Bit, BR10640 Only. (3 Pack)	BR10640	1
9	BR10631	4 inch (102 mm) Auger Blade (3 Pack)	BR10641	1
10	BR10632	6 inch (152 mm) Auger Blade (3 Pack)	BR10642	1
11	BR10633	8 inch (203 mm) Auger Blade (3 Pack)	BR10643	1
12	52050000	Nut, Lock, 2-Way, 5/16-18, ZY	BR10641 Thru BR10643	1
13	BR10621	Screw Bit (3 Pack)	BR10641 Thru BR10643	1

*THIS PAGE INTENTIONALLY
LEFT BLANK*