

BRAVE

MBRP500TP2

ITEM NUMBER(S): BRP500TP2, BRP520TP3, BRP650HP2

MANUAL SERIAL TAG HERE



Owner's Manual Brave Water Pump

▲ WARNING

Read and understand all instructions.

Failure to follow all instructions may result in serious injury or property damage.

WARNING: Wear appropriate protective gear. This list includes, but is not limited to:

-safety glasses, protective boots with slip resistant soles, gloves, hearing protection.

- **WARNING:** Keep guards in place and in working order. Never operate the product without the guards in place.
- **WARNING:** LETHAL EXHAUST GAS! An internal combustion engine discharges carbon monoxide, which is a poisonous and odorless invisible gas. Death or serious illness may result if inhaled. Operate only in an area with good ventilation.
- **DANGER:** Do not smoke when refueling.
- **WARNING:** Do not use pump in explosive atmosphere.
- **WARNING:** Do not pump volatile or flammable liquids such as gasoline, fuel oil, kerosene, etc.
- **CAUTION:** Do not attempt to operate pump, if any parts are missing or damaged.
- **CAUTION:** For proper handling techniques and cautions when pumping certain chemicals, contact your chemical supplier or local agencies (fire dept etc)
- **CAUTION:** The engine is hot enough to cause injury, do not touch the exterior of the engine, especially the muffler and surrounding area.
- **WARNING:** Even though this unit will operate with minimal supervision, it should not be left operating by itself. Depending on the application and area unit is operating (high traffic, people in area, etc.) will dictate the necessity of having someone watching over the unit.
- **CAUTION:** Do not allow pump to be located in freezing or colder weather. Damage to pump will result.
- **CAUTION:** Do not run pump dry, as permanent damage to the mechanical seal will result.

STOP!

ADD OIL TO ENGINE BEFORE USING: Engine is shipped without oil. DO NOT start engine without first adding oil.
INSPECT COMPONENTS: Closely inspect to make sure no components are missing or damaged.

**Any Questions, Comments, Problems or Parts Orders
Call Brave Support 1-800-350-8739**

Please read and save this Owner's Manual. Read this manual carefully before attempting to operate or maintain this pump. Protect yourself and others by observing all safety information. Failure to comply with the safety instructions accompanying this product could result in personal injury and/or property damage! Retain instructions for future reference. Brave reserves the right to discontinue any model or change specifications at any time without incurring any obligation.

Periodic maintenance and inspection is required on all pumps to ensure proper operation. Unit must be clear of debris and sediment. Inspect for leaks and loose bolts. Failure to do so voids warranty.

Brave Water Pumps

DESCRIPTION

Brave engine driven pumps are commercial duty, centrifugal, self-priming (to 25 ft. vertical lift after initially filling casing with liquid), portable units. Pumps are equipped with industry standard mechanical shaft seals. Iron suction and discharge manifolds are standard male NPT threads for direct connection to swivel hose fitting with gasket, or standard NPT pipe fittings. Discharge manifold can be rotated 180° (in 90° increments); left side discharge, front discharge or right side discharge. Pump components will handle liquids with a temperature range of 40° to 180°F (4° to 82° C). Pump only nonflammable liquids compatible with pump component materials. Brave pumps are close coupled to internal combustion engines manufactured by Honda. All engines meet current EPA emissions requirements.

SPECIFICATIONS

Standard units are constructed of cast aluminum with cast iron impeller ("P" series - cast aluminum), cast iron volute, and cast iron suction and discharge manifolds. Standard seals are EPDM with silicon-carbide ("P" series - carbon-ceramic) wear faces.

UNPACKING

1. Remove pump from packaging materials.
2. Package should include: pump/engine mounted in roll frame, strainer, general/safety manual, specification/parts manual, engine manual.
3. Make sure all components are accounted for before discarding packaging material.
4. Inspect all components for damage.
5. No assembly is required for standard engine driven pumps.

PREPARING UNIT FOR OPERATION

Placing Pump

1. Always place the pump as close to the liquid source as possible. Priming efficiency and pump output will be reduced if a long (>25 ft.) suction line is used. Keep all lines as short and straight as possible. Avoid any sharp bends. Suction line cannot have loops or high spots, hose must have a gradual slope up to pump.
2. Pump/engine must be located on a solid level surface.

Connecting Hose or Piping

1. All suction hose/piping connection must be air tight. Pump will not prime if there are any air leaks in the suction line or connections.
2. Use only non-collapsible hose or pipe on the suction. If collapsible hose is used on the discharge, the end of discharge line is submerged in liquid, or a check valve is placed in the discharge line, a means of venting air out of the pump during the priming cycle must be employed.
3. Always use a suction strainer to keep large debris out of the pump. Position strainer well below liquid surface and on a bed of rocks or other suitable surface. If possible tie strainer up so it is suspended off pit bottom. As a

last resort tie the strainer in a large submerged bucket if bottom of water source is too soft or muddy.

Before Starting Engine

1. Fill engine crankcase with oil. Follow engine manufacturer recommendations for service classification and viscosity of oil as detailed in engine manual.
2. Fill fuel tank with clean, fresh, fuel. Follow engine manufacturer's guidelines as listed in engine manual.
3. Always fill pump with liquid through the priming port located on top of the discharge manifold or pump casing before starting engine. Remember the pump is self-priming only when the pump is filled with liquid.

Operation

1. Make certain pump is filled with liquid before starting engine. Failure to do so will result in damage to the mechanical shaft seal. Never run pump dry.

▲ WARNING

DO NOT USE PUMP IN EXPLOSIVE ATMOSPHERE. DO NOT PUMP VOLATILE OR FLAMMABLE LIQUIDS.

2. Follow engine manufacturer's starting procedure. Run engine at full speed during priming. After pump has primed speed may be reduced to regulate pump output.
3. Pump will self-prime to a vertical height of 10' in less than one minute, 20' in 2 minutes, 25' may take up to 4 minutes. If pump doesn't prime: Check for air leaks, move pump closer to liquid, shorten suction line, remove loops and high spots from suction line, refill pump with liquid, see troubleshooting guide in this manual.
4. Always allow engine to cool before refueling.

After Pump is Shut Down

1. Always flush the pump out at the end of operation if the liquid being pumped may leave a solid or sticky residue inside of pump, or if a buildup of sediment inside the pump is expected.
2. Always drain pump completely of liquid if there is a chance of freezing.

Storing Pump

1. When pump is out of service for an extended period of time, completely drain liquid from casing, store pump in a dry, protected, well-ventilated area.
2. Add fuel stabilizer to engine fuel tank or drain fuel from tank. Turn fuel tank valve to off position.

COMPLETE PUMP ASSEMBLY PROCEDURE

Reference Repair/Replacement Part Exploded View and Lists

NOTE: Do not use petroleum based lubricants with EPDM rubber seal parts and O-rings. Petroleum based products will damage EPDM components.

NOTE: Apply a small amount of anti-seize lubricant to bore, threaded or keyed, in impeller. If petroleum based anti-seize lubricant is used do not allow it to contact EPDM components.

Install Seal Stationary Half

1. Lay bracket (Ref. No. 2) on a solid surface, engine mount down. Apply silicone sealant (Loctite® RTV or similar) to outside metal case of shaft seal stationary half (Ref. No. 8). Position in cast bore of the bracket with polished seal ring up. Install by pressing on metal housing of the seal with a piece of plastic pipe or similar stock until metal case lip seats against bracket. Do not press on lapped seal surface to install.

Install Shaft Collar - 5/8-18 threaded "P" & "S" pumps and kits:

1. Install shaft collar (Ref. No. 10) on PTO shaft. Orient large inside diameter chamfer towards PTO shaft shoulder. Slide collar down shaft until it contacts PTO shaft shoulder.

Install Bracket

1. Lay engine (Ref. No. 1) down on recoil starter with PTO shaft up vertical. Clean PTO shaft and mounting surface.
2. Install adapter gasket (Ref. No. 37) onto the PTO shaft.
3. Position bracket on engine. Fit locating diameter on back of bracket into PTO bearing bore in engine crankcase cover. Make sure all four bolt bosses on bracket sit flat on engine crankcase cover. Rotate until bracket feet align with engine block mounting base.
4. Install four O-rings (Ref. No. 7) on four screws (Ref. No. 6). Install screws through bracket into engine crankcase cover making sure O-rings seat in cast counter bore of bolt hole. Torque screws to 140 in-lb.

Install Closed Impeller -3/4" keyed "P" pump kits

1. Temporarily install impeller (Ref. No. 11) on PTO shaft. If impeller hits inside of bracket before bottoming against PTO shaft end insert shims (Ref. No. 12) between end of PTO shaft and impeller until 0.60" clearance is achieved. Remove impeller from PTO shaft.

NOTE: The .060 clearance is critical to prevent interference of the impeller hitting the bracket potentially causing the pump to seize.

2. Insert key (Ref. No. 14) into impeller keyway.
3. Install shaft seal rotating half (Ref. No. 8) into bore in impeller hub. Lubricate rubber cup of the seal with soapy water. Position in impeller hub bore with polished face out. Protect polished face of the seal from damage with a piece of cardboard or cloth. Press seal into bore until it bottoms.

4. Install O-ring (Ref. No. 16) into bore in front of impeller nose. Slide impeller screw (Ref. No. 15) into through hole. If required install shims inside impeller bore, position on exposed screw end.
5. Align key with PTO shaft keyway. Slide impeller onto PTO shaft. Fix on shaft with screw. Torque screw to 140 in-lb.

Install Semi-Open Impeller -3/4" keyed "S" pump kits

1. Temporarily install impeller (Ref. No. 11) on PTO shaft. End of PTO shaft must contact bottom of shaft bore in impeller hub. If impeller rear shroud contacts bracket before end of PTO shaft contacts bottom of shaft bore in impeller, install shims (Ref. No. 12) in bore until impeller clears bracket.
2. Measure normal distance from impeller vane front face to bracket inside face with a micrometer or similar accurate measuring instrument.
3. Lay volute (Ref. No. 18) on its nose exposing bracket mounting surface. Measure normal distance from volute mounting surface to impeller wear face.
4. Adjust amount of impeller shims until assembled clearance between impeller face and volute face is 0.01" to 0.03". Remove impeller from shaft.
5. Insert key (Ref. No. 14) into impeller keyway.
6. Install shaft seal rotating half (Ref. No. 8) into bore in impeller hub. Lubricate rubber cup of the seal with soapy water. Position in impeller hub bore with polished face out. Protect polished face of the seal from damage with a piece of cardboard or cloth. Press seal into bore until it bottoms.
7. Install O-ring (Ref. No. 16) into bore in front of impeller nose. Slide impeller screw (Ref. No. 15) into center hole through impeller. If required install shims used to set impeller clearance inside impeller bore, position on exposed screw end.
8. Align key with PTO shaft keyway. Slide impeller onto PTO shaft. Fix on shaft with screw. Torque screw to 140 in-lb.

Install Volute

1. Lay volute (Ref. No. 18) on its nose exposing bracket mounting surface. Install O-ring (Ref. No. 17) into groove.
2. Position volute on pins (Ref. No. 5) installed in bracket. Volute will go on only one way, with discharge opening to the top. Slide volute on pins until it seats against bracket.
3. Secure volute to bracket with screws (Ref. No. 19). Torque screws to 50 in-lb.

Install Casing

1. Install check valve (Ref. No. 21) on volute nose. Make certain valve is oriented correctly with flapper hinge at the top. Align notch in mounting ring with rib cast into top of volute nose.
2. Install casing O-ring (Ref. No. 20) onto casing (Ref. No. 22). Lubricate with soapy water.
3. Install casing onto bracket. Screws (Ref. No. 27) are held into casing body with O-rings (Ref. No. 28) and square nuts (Ref. No. 4) are held into bracket ears with clips (Ref. No. 3) to make installation easier. Align casing to bracket and install six screws. Torque screws to 100 in-lb.

Install Ports and Plugs

1. Install an O-ring (Ref. No. 30) on each of two plugs (Ref. No. 29). Thread one plug into fill port on discharge manifold (Ref. No. 24) and one plug into casing drain port.
2. Align a gasket (Ref. No. 26) onto discharge flange of casing. Install discharge manifold onto casing with four screws (Ref. No. 25). Torque screws to 100 in-lbs., alternate tightening screws in a cross pattern to eliminate crushing the gasket.
3. Align a gasket (Ref. No. 26) onto suction flange of casing. Install suction flange (Ref. No. 23) onto casing with four screws (Ref. No. 25). Torque screws to 100 in-lbs., alternate tightening screws in a cross pattern to eliminate crushing the gasket.

casing to bracket connection, suction and discharge manifold connections, and through pump casing and bracket. Investigate and repair any leaks immediately.

NOTE: Engine failure due to water intrusion into crankcase caused by a leaking seal will not be covered by engine or pump warranty.

5. Mechanical shaft seals are a wear item and require periodic replacement. Seal life is dependent on many factors including liquid pumped, sediment type, operating point, and suction conditions.
6. Inspect for loose fasteners. Tighten any loose fasteners immediately.

REPAIR AND MAINTENANCE INSTRUCTIONS**Shaft Seal Replacement**

1. Loosen six screws (Ref. No. 27) until screw disengages square nut (Ref. No. 4) in bracket.
2. Remove casing assembly from bracket.
3. Remove screws (Ref. No. 19) holding volute (Ref. No. 18) to bracket.
4. Remove volute.
5. Remove impeller (Ref. No. 11). Keyed shaft impellers; remove impeller screw (Ref. No. 15), inspect O-ring (Ref. No. 16) replace if required.
6. Pry worn rotating half of shaft seal (Ref. No. 8) from impeller hub. Discard seal.
7. Remove screws (Ref. No. 6) holding bracket to engine, inspect O-rings (Ref. No. 7), replace if required.
8. Remove bracket from engine.
9. Press stationary half of shaft seal (Ref. No. 8) from bracket. Discard seal.
10. Replace any O-rings (Ref. Nos. 17 & 20) that show signs of wear or damage.
11. Rebuild pump with new shaft seal. Follow Pump End Assembly Instructions.

Cleaning Pump

1. Loosen six screws (Ref. No. 27) until screw disengages square nut (Ref. No. 4) in bracket.
2. Remove casing assembly from bracket.
3. Remove screws (Ref. No. 19) holding volute (Ref. No. 18) to bracket.
4. Remove volute.
5. Clean debris and sediment from inside of casing, volute, and impeller. Clean all volute passages and impeller vanes. Make sure closed impeller vane passages are clean by running a wire from impeller outside diameter to impeller eye. Remove any foreign objects clogging passages.
6. Check all parts for excessive wear or damage. Replace parts as required.
7. Reassemble pump.

Periodic Maintenance

1. Clean outside of pump and engine to remove accumulated dirt, oil and grime.
2. Maintain engine according to engine manufacturer's recommendations.
3. It is recommended that a replacement shaft seal and seal kit be kept on hand at all times.
4. Check for leaks during pump operation. Leaks may occur at shaft seal,

Problem	Possible Cause(s)	Corrective Action
Pump fails to prime	<ol style="list-style-type: none"> 1 Pump not filled with liquid 2 Air leak at suction line connection 3 Worn suction connection gasket 4 Leaking suction line 5 Engine speed too low 6 Worn or broken volute or impeller 7 Leaking/worn mechanical shaft seal 8 Clogged suction strainer/line 9 Suction lift too great (25 ft. max) 10 Suction line too long 11 Pump is air locked 	<ol style="list-style-type: none"> 1 Add liquid to pump through priming port 2 Add sealant to connection 3 Replace suction gasket 4 Inspect, repair or replace suction line 5 Run engine at maximum speed 6 Replace parts as required 7 Replace mechanical shaft seal 8 Clean strainer and suction line 9 Reduce lift 10 Reduce length to under 30 feet 11 Vent pump discharge through priming port
<p>Priming remedies that will NOT work:</p> <ol style="list-style-type: none"> 1. Holding suction line out of liquid source and forcing liquid into end while pump is running 2. Pinching off the discharge line to “build up pressure”. 3. Holding hand against end of suction line or pump suction port to “feel” for suction. <p>Follow above priming troubleshooting guide.</p> <p>If pump still will not prime after all corrective action is exhausted, check pump priming capacity by:</p> <ol style="list-style-type: none"> 1. Install a vacuum gauge on capped suction port. Gauge to suction port connection must be 100% air tight. 2. Fill pump casing completely with water. 3. Run pump at full speed, some water will be thrown out of discharge. 4. Vacuum gauge should register 18-22 inches of mercury within a minute or so. <ol style="list-style-type: none"> a. If vacuum registers below 18 in of hg check gauge to pump connection for air leaks, inspect/replace volute, impeller and shaft seal as required. b. If vacuum gauge value is within range pump is working correctly. The problem is not the pump. 		
Reduced capacity or discharge pressure	<ol style="list-style-type: none"> 1. Clogged strainer or lines 2. High friction loss in line 3. Discharge head too high 4. Engine speed too low 5. Drop in engine output 6. Clogged impeller 7. Worn/damaged impeller or volute 	<ol style="list-style-type: none"> 1. Clean strainer, suction and discharge lines 2. Remove kinks and elbows, reduce length 3. Lower end of discharge line, remove nozzles 4. Increase engine speed 5. Repair engine 6. Remove clog 7. Replace parts as required
Pump will not work/engine will not turn over	<ol style="list-style-type: none"> 1. Clogged pump 2. Pump parts rusted together 3. Damaged impeller or volute 4. Engine seized 	<ol style="list-style-type: none"> 1. Remove clog between impeller and volute 2. Disassemble pump, free parts 3. Replace volute or impeller 4. Remove pump from engine, check engine itself
Pump will not work/engine runs	<ol style="list-style-type: none"> 1. Impeller stripped/key sheared 2. Pump impeller/volute clogged 3. Will not prime 4. Insufficient liquid supply 	<ol style="list-style-type: none"> 1. Disassemble pump, replace parts/engine 2. Clean pump 3. See Priming Troubleshooting Section 4. Increase liquid supply

BRP650HP2, BRP500TP2, BRP520TP3 Pumps

For Repair Parts contact dealer where pump was purchased.

Please provide following information:

-Model Number

-Serial Number (if any)

Part description and number as shown in parts list

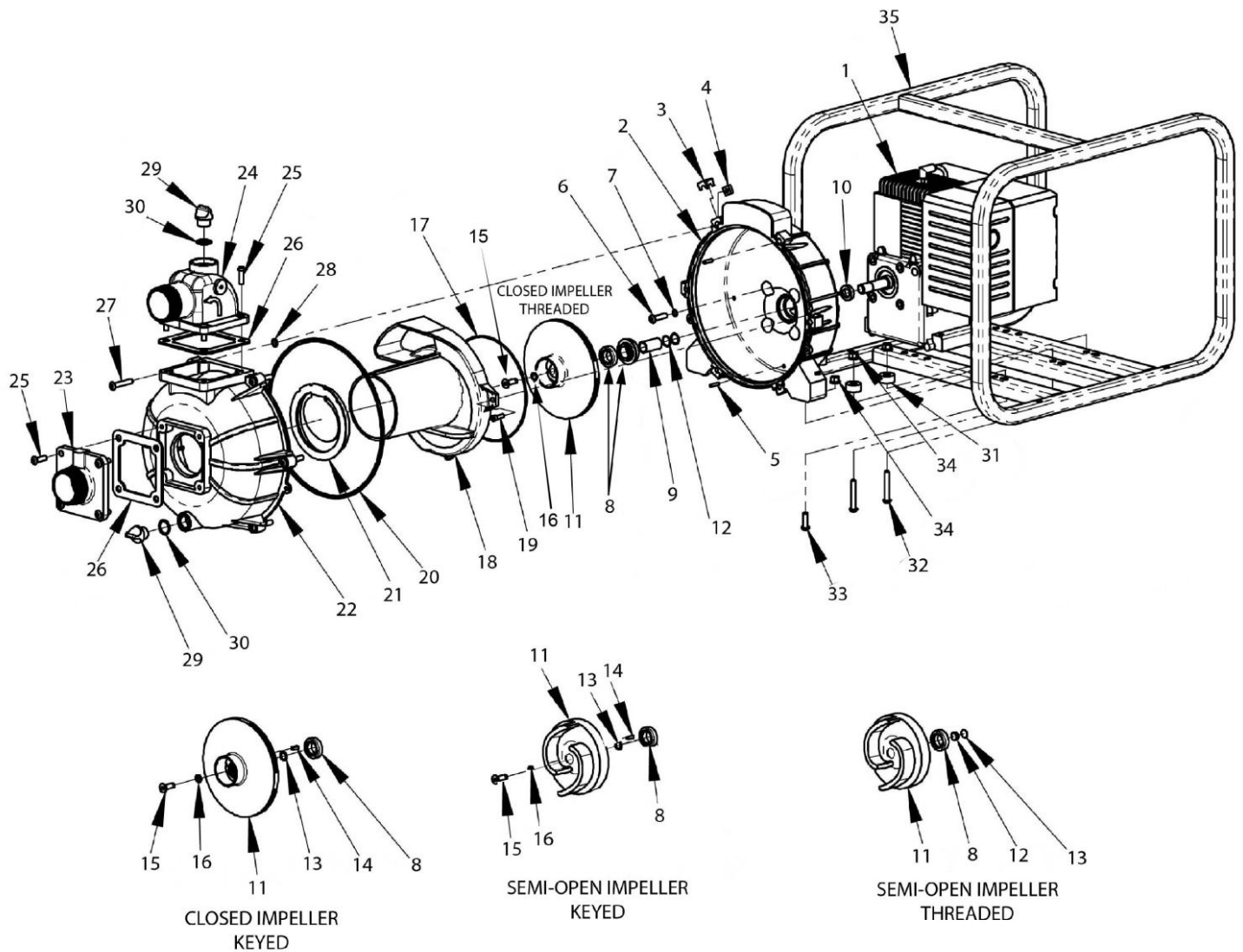

Figure 1 - Repair Parts Illustrations

Repair Parts List

Ref. No.	Description	2" Hi Pressure	2" Trash	3" Trash	Qty. Req'd
		BRP650HP2 (Threaded Shaft)	BRP500TP2 (Threaded Shaft)	BRP520TP3 (Threaded Shaft)	
1	Engine	See table	See table	See table	1
2	Adapter Kit (Gasoline Engines) (includes Ref. Nos. 2, 3, 4 & 5)	3S5X-035-96	3S5X-035-96	3S5X-035-96	1
	Adapter Kit (Diesel Engines) (includes Ref. Nos. 2, 3, 4 & 5)	3S5X-036-96	3S5X-036-96	3S5X-036-96	1
3	Keeper clip	Incl. w/Ref 2	Incl. w/Ref 2	Incl. w/Ref 2	6
4	5/16-18 Square Nut	Incl. w/Ref 2	Incl. w/Ref 2	Incl. w/Ref 2	6
5	3/16x3/4" Slotted Spring Pin	Incl. w/Ref 2	Incl. w/Ref 2	Incl. w/Ref 2	2
6	5/16-24 Screw	Incl. w/Ref 2	Incl. w/Ref 2	Incl. w/Ref 2	4
7	#011 O-Ring	Incl. w/Ref 36	Incl. w/Ref 36	Incl. w/Ref 36	4
8	Seal Assembly-EPDM	1640-162-93	N/A	N/A	1
	Seal Assembly-Silicon Carbide/ Viton	Optional 3-258-A	3-258-A	3-258-A	1
9	Shaft Sleeve/Collar Kit	2P5X-140-90 & Incl. w/Ref 11	2S5X-140-90 & Incl. w/Ref 11	2S5X-140-90 & Incl. w/Ref 11	1
10	Shaft Collar	Incl. w/Ref 9 & 11	Incl. w/Ref 9 & 11	Incl. w/Ref 9 & 11	1
11	Impeller Kit (5/8) (includes Ref. Nos. 9, 10,11,12,13,14,15 (if required))	2P5X-010-96	2S5T-010-95	3S5X-010-95	1
	Impeller Kit (3/4) (includes Ref. Nos. 9, 10,11,12,13,14,15 (if required))	2P5T-010-96	2S5X-010-95	N/A	1
12	Impeller Spacer	N/A	Incl. w/Ref 11	Incl. w/Ref 11	1
13	Impeller Shim (if required)	Incl. w/Ref 11	Incl. w/Ref 11	Incl. w/Ref 11	1
14	3/16 square x 1/2" long Key	N/A	N/A	N/A	1
15	5/16-24 Flat Head Screw	N/A	N/A	N/A	1
16	#109 O-Ring	N/A	N/A	N/A	1
17	#167 O-Ring ("P" Series)	Incl. w/Ref 36	N/A	N/A	1
	#160 O-Ring ("S" Series)	N/A	Incl. w/Ref 36	Incl. w/Ref 36	1
18	Volute Kit (includes Ref. Nos. 18 & 19)	2P5X-150-95	2S5X-150-95	3S5X-150-95	1
19	1/4-20 Cap Screw	Incl. w/Ref 18	Incl. w/Ref 18	Incl. w/Ref 18	2
20	#378 O-Ring	Incl. w/Ref 36	Incl. w/Ref 36	Incl. w/Ref 36	1
21	Check Valve	7-137-1 & Incl. w/Ref 36	7-137-1 & Incl. w/Ref 36	7-137-1 & Incl. w/Ref 36	1
22	Casing Kit (includes Ref. Nos. 22, 27 & 28)	3S5X-005-96	3S5X-005-96	3S5X-005-96	1
23	Suction Flange Kit (includes Ref. Nos. 23 & 25)	2S5X-050-95	2S5X-050-95	3S5X-050-95	1
24	Discharge Manifold Kit (includes Ref. Nos. 24 & 25)	2S5X-080-95	2S5X-080-95	3S5X-080-95	1
25	5/16-18 Cap Screw	Incl. w/ Ref 23 & 24	Incl. w/ Ref 23 & 24	Incl. w/ Ref 23 & 24	8
26	Gasket	Incl. w/Ref 36	Incl. w/Ref 36	Incl. w/Ref 36	2
27	Cap Screw	Incl. w/ Ref 22	Incl. w/ Ref 22	Incl. w/ Ref 22	6
28	Bolt Keeper	Incl. w/ Ref 22	Incl. w/ Ref 22	Incl. w/ Ref 22	6
29	Fill Plug	Incl. w/Ref 36	Incl. w/Ref 36	Incl. w/Ref 36	2
30	#117 O-Ring	Incl. w/Ref 36	Incl. w/Ref 36	Incl. w/Ref 36	2
31	Spacer	Incl. w/ Ref 35A	Incl. w/ Ref 35A	Incl. w/ Ref 35A	4 or 2
32	Cap Screw	Incl. w/ Ref 35A	Incl. w/ Ref 35A	Incl. w/ Ref 35A	4 or 6
33	Cap Screw	Incl. w/ Ref 35A	Incl. w/ Ref 35A	Incl. w/ Ref 35A	2
34	Hex Flange Nut	Incl. w/ Ref 35A	Incl. w/ Ref 35A	Incl. w/ Ref 35A	6

Repair Parts List - CONTINUED

Ref.		2" Hi Pressure	2" Trash	3" Trash	Qty.
No.	Description	BRP650HP2 (Threaded Shaft)	BRP500TP2 (Threaded Shaft)	BRP520TP3 (Threaded Shaft)	Req'd
35	Frame Kit (if required)	3120-IPT-K0	3120-IPT-K0	3120-IPT-K0	1
35A	Frame Hardware Kit (If required) Gas Engine	3120-105-95	3120-105-95	3120-105-95	1
36	EPDM O-Ring/ Check Valve/ Gasket Kit (includes Ref. Nos. 7, 16, 17, 20, 21, 26, 29 & 30 (if required))	2PXE-300-90	2SXE-300-90	2SXE-300-90	1
	Viton (Optional) O-Ring/Check Valve/Gasket Kit (includes Ref. Nos. 7, 8, 16, 17, 20, 21, 26, 29 & 30 (if required))	2PXV-300-90	2SXV-300-90	2SXV-300-90	1
37	Adapter Gasket	Incl. w/Ref 36	Incl. w/Ref 36	Incl. w/Ref 36	1
39	Strainer -(not shown)	44-315	1679-001-00	1681-000-00	1

Please read and save this Owner's Manual. Read this manual carefully before attempting to operate or maintain this pump. Protect yourself and others by observing all safety information. Failure to comply with the safety instructions accompanying this product could result in personal injury and/or property damage! Retain instructions for future reference.

Periodic maintenance and inspection is required on all pumps to ensure proper operation. Unit must be clear of debris and sediment. Inspect for leaks and loose bolts. Failure to do so voids warranty.

Engine-Driven Centrifugal Pumps

SAFETY GUIDELINES

This manual contains information that is very important to know and understand. This information is provided for SAFETY and to PREVENT EQUIPMENT PROBLEMS. To help recognize this information, observe the following symbols:

DANGER

Danger indicates an imminently hazardous situation which, if not avoided, WILL result in death or serious injury.

WARNING

Warning indicates a potentially hazardous situation which, if not avoided, COULD result in death or serious injury.

CAUTION

Caution Indicates a potentially hazardous situation which, if not avoided, MAY result in minor or moderate injury.

NOTE: *Indicates important information that, if not followed, may cause damage to equipment.*

UNPACKING

After unpacking the unit, inspect carefully for any damage that may have occurred during transit. Make sure to tighten fittings, bolts, etc., before putting unit into service.

CAUTION

Do not attempt to assemble or operate pump if any parts are missing or damaged. Determine that all parts are properly installed.

GENERAL SAFETY INFORMATION

1. Know the pump application, limitations, and potential hazards. Read all manuals included with this product carefully. Be thoroughly familiar with the pump and the proper use of the equipment.



DANGER

Do not use to pump flammable or explosive fluids such as gasoline, fuel oil, kerosene, etc. Do not use in flammable and/or explosive atmospheres. When pumping hazardous or dangerous materials, use only in room or area designated for that purpose. For your protection, always wear

proper clothing, eye protection, etc. in case of any malfunction. For proper handling techniques and cautions, contact your chemical supplier, insurance company and local agencies (fire dept., etc.). Failure to comply with this warning could result in personal injury and/or property damage.

2. Make certain that the power source (engine) conforms to the requirements of your equipment.
3. Provide adequate protection and guarding around moving parts.
4. Release all pressure within the system before servicing any component.
5. Drain all liquids from the system before servicing.
6. Secure the discharge line before starting the pump. An unsecured discharge line will whip, possibly causing personal injury and/or property damage.
7. Check hoses for weak or worn condition before each use, making certain that all connections are secure.
8. Periodically inspect pump and system components. Perform routine maintenance as required (See Maintenance section).
9. Provide a means of pressure relief for pumps whose discharge line can be shut-off or obstructed.
10. **Personal Safety:**
 - a.. Wear safety glasses at all times when working with pumps.
 - b. Wear a face shield and proper apparel when pumping hazardous chemicals.
 - c. Keep work area clean, uncluttered and properly lighted; replace all unused tools and equipment.
 - d. Keep visitors at a safe distance from the work area.
 - e. Make workshop childproof – with padlocks, master switches, and by removing starter keys.
11. Carefully read instruction manuals supplied by engine manufacturer before attempting to assemble, operate, or service the engine or any part. The WARNING statements indicate potentially hazardous conditions for operator or equipment. TAKE NECESSARY STEPS TO PROTECT PERSONNEL AND EQUIPMENT.

WARNING

Gasoline is a highly combustible fuel. The improper use, handling, or storage of gasoline can be dangerous. Prevent accidents by following these safety rules:

- a. Use gasoline only as fuel, never as a cleaning fluid.
- b. Use only an approved container to hold or store gasoline. Never store gasoline in familiar containers such as milk containers or soda pop bottles.
- c. Store gasoline in a cool location, out of reach of children. Never store gasoline near heat or an open flame.
- d. Add gasoline to a cool engine only. Spilled gasoline on a hot engine may cause fire or an explosion. Fill gasoline tank outdoors and wipe up any spills.
- e. Provide a fire extinguisher nearby when working with gasoline. Be

Engine-Driven Centrifugal Pumps

sure extinguisher is in operating condition – check the pressure gauge or indicator. Be familiar with its proper use. Consult local fire department for the correct type of extinguisher for your application. Extinguishers rated ABC by the National Fire Protection Association are appropriate for most applications.

IMPORTANT: Positively no smoking!

1. DO NOT RUN THE ENGINE IN AN ENCLOSED AREA!! Exhaust fumes contain carbon monoxide, which is an odorless and poisonous gas. If equipment is located in an enclosed area, use an exhaust line to the outside and regularly check the exhaust system for leaks. Be sure the area is well ventilated.
2. Check engine oil and fuel levels before initial startup each day. Stay away from moving parts. Avoid wearing loose jackets, shirts and ties. Make sure all nuts and bolts are secure. Keep power shields and guards in place. If adjustments must be made while the unit is running, use extreme caution around hot manifolds, moving parts, etc.
3. Do not operate this equipment when mentally or physically fatigued.

CAUTION

Be careful not to touch the exterior of the engine, especially the muffler and the surrounding area. The engine is hot enough to be painful or cause injury!

4. Prevent accidental starting by always removing spark plug or by disconnecting and grounding spark plug wire before working on engine or the equipment driven by engine.
5. Familiarize yourself with all controls. Learn how to stop an engine quickly in an emergency.
6. Keep the equipment and surrounding area clean. Remove all oil deposits from equipment and surrounding area. Accumulations of grease and oil may present a fire hazard and can cause engine damage. Cleaning rags and other flammable waste materials must be stored in approved metal containers.
7. All visitors should be kept at a safe distance from the working area. Keep children away from power equipment. Keep work area clean. Cluttered areas invite accidents.
8. When shutting off a gasoline engine, be sure it is completely stopped before leaving the work area.

INSTALLATION

WARNING

The pumps should not be used in flammable or explosive atmospheres. In order to safely use this product, familiarize yourself with this pump and also with the liquid (chemical, etc.) that is going to be pumped through the unit. This pump is not suitable for many liquids.

IMPORTANT: For installations where property damage might result from an inoperative or leaking pump due to power outages, discharge line blockage or any other reason, a back-up system(s) and/or warning system(s) should be used.

1. Locate pump as close to the fluid source as possible, making the suction line as short and direct as possible.

CAUTION

The unit should be placed where the pump/engine is protected from the weather and extremes of heat, cold and humidity.

2. Mount the unit on a solid foundation. On fixed installation, install both a union and a gate valve (not furnished) on the discharge side of the pump for service convenience.

CAUTION

Do not use a globe or other restricting type of valve at the discharge, as this would seriously restrict the capacity of the pump.

3. Attach suction line piping to the suction inlet and discharge line piping to the discharge outlet. The suction line should be positioned such that there is a continual upward slope from the fluid source to the pump. Avoid using loops or sections of pipe or fittings which might permit air to become trapped.

IMPORTANT: If plastic or fabric hose is used for the suction piping, it should be of a reinforced type so as not to collapse under suction. The discharge piping should be at least the same size as the discharge connection. Suction piping should be the same size as the discharge piping or one size larger. Unless long horizontal runs are involved, discharge piping should not be larger than suction piping. Avoid using looped sections of pipe, which might permit air to become entrapped. Assure air-tight pipe connections with the use of a pipe joint sealant.

4. **Fill pump with liquid.** A foot-valve may be used on the suction line to assist in faster pumping. The foot-valve should be installed when the suction lift is over 10 feet or when the suction line is over 10 feet long.

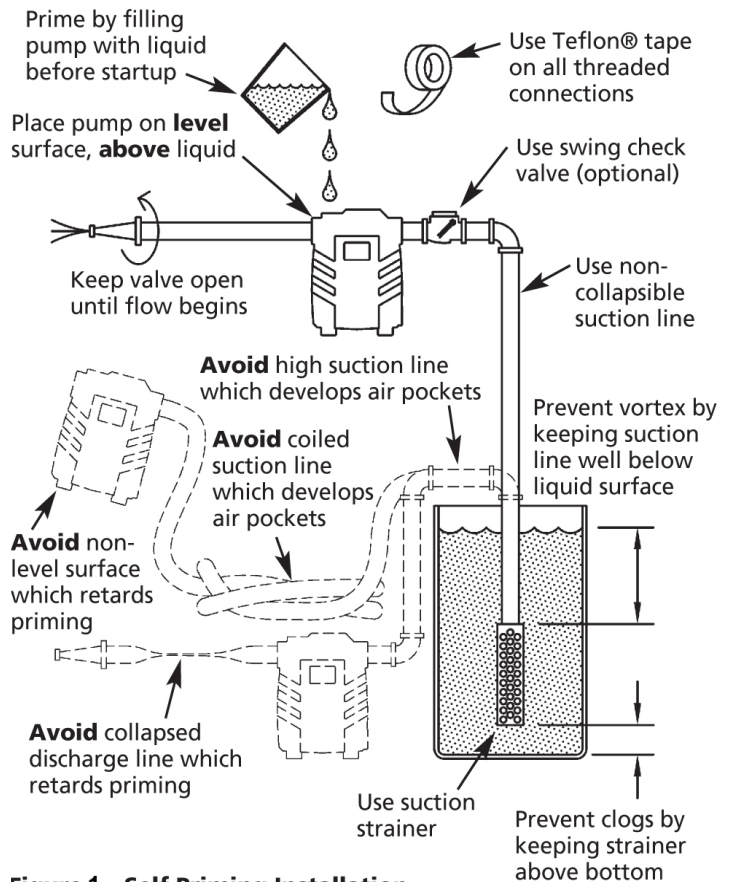

Figure 1 - Self Priming Installation

Engine-Driven Centrifugal Pumps

5. A suitable suction strainer should be attached to the suction line so that large pieces of foreign material are not drawn into the pump. The maximum opening in the suction strainer should not be greater than 25% of the suction inlet size for solid handling pumps and 50% of the suction inlet size for trash pumps.
2. Clean the suction line strainer at regular intervals.
3. If the engine is equipped with a spark arrestor screen in the muffler, it should be inspected for wear periodically and replaced when necessary.

NOTE: For information pertaining to the engine and engine parts, consult the Engine Manual or contact the nearest authorized service representative or the manufacturer.

OPERATION

1. **OIL:** Fill the engine crankcase with oil as specified in the engine manual. Periodically check oil level thereafter and service stated in engine manual.
2. **FUEL:** Fill the fuel tank as required for engines. Refer to engine instruction booklet for proper fuel type.
3. **OTHER:** Fill any other required fluid such as antifreeze, etc. (if required by engine manufacturer).

4. Periodically check nuts and bolts on engine, mounting frame and pump. Since this is a gas engine pump, vibration levels tend to loosen nuts and bolts faster than normal. Use Loctite (thread sealant) on threads or lock washers if necessary.

▲ WARNING

Never add gasoline to a hot engine! See General Safety Information for proper handling of gasoline.

4. Fill the pump with liquid through the pump priming port supplied with these units. The pump should prime and re-prime without refilling. Refilling is necessary occasionally if an unusual siphoning has occurred, if the fluid has been lost by evaporation, and when the unit is moved to a new location.

▲ CAUTION

Do not run pump dry, as permanent damage to the mechanical seal will result.

5. Start the engine, following instructions in the engine manual.
6. With a suction lift of 5 to 10 feet, the pump should discharge liquid within one or two minutes. A suction lift of 20 feet can take 5 minutes of running time to pick up a prime. If pumping does not start within this time, shut off the engine, let unit cool down about 5 minutes, refill pump casing and retry. If engine does not start, refer to Engine Manual. If pump does not prime after two tries, refer to "Troubleshooting Chart" in this manual.
7. Properly fueled and lubricated, the pump/engine unit will run automatically without attention to the controls. The gasoline engine has a built-in governor and will adjust the speed of the engine automatically depending on the volume of water being delivered.

▲ WARNING

Even though this unit will operate with minimal supervision, it should not be left operating by itself. Depending on the application and area unit is operating (high traffic, people in area, etc.) will dictate the necessity of having someone watching over the unit.

MAINTENANCE

NOTE: Always flush pump thoroughly after use or if unit is not going to be used for any prolonged length of time to prevent crystallization and/or damage to seal and pump.

ROUTINE

1. Pump should be drained when subjected to freezing temperatures. A drain plug is provided on the pump casing.



Dear Valued Customer:

The Brave product you just purchased is built with the finest material and craftsmanship. Use this product properly and enjoy the benefits from its high performance. By purchasing a Brave product, you show a desire for quality and durability. Like all mechanical equipment this unit requires a due amount of care. Treat this unit like the high quality piece of machinery it is. Neglect and improper handling may impair its performance.

Thoroughly read the instructions and understand the operation before using your product. Always contact Brave Product Support at 1-800-350-8739 prior to having any service or warranty work performed, as some services performed by parties other than Brave approved service centers may void this warranty. This limited warranty is in lieu of any other warranty expressed or implied, written or oral and Brave assumes no other responsibility or liability outside that expressed within this limited warranty.

Limited Warranty for Brave Pump Models:

BRP160SP2	BRP500TP2	BRP650HP2
BRP160SP3	BRP520TP3	BRP750DP3
BRP200TP3	BRP550TP3	

	Consumer Warranty Period	Commercial Warranty Period
Complete Unit	2 years from date of purchase by user	1 year from date of purchase by user
Wear Parts	In addition to the normal warranty, Brave shall warrant some normal wear items from defects in material or workmanship for a period of 30 days from the date of purchase by user. Normal wear items covered under this warranty are limited to: Mechanical Seals	
Engines	The engine warranty is covered under the terms and conditions as outlined by the engine manufactures warranty contained herein and is the sole responsibility of the engine manufacturer. Normal engine maintenance such as spark plugs, oil changes, air filters, adjustments, fuel system cleaning and obstruction due to build up is not covered by this Brave limited warranty.	

“**Consumer use**” means personal residential household use by a consumer. “**Commercial use**” means all other uses, including, but not limited to, use for commercial, income producing or rental purposes or when purchased by a business.

This limited warranty applies to the original purchaser of the equipment (verification of purchase, in the form of a receipt, is the responsibility of the buyer), is non-transferable, and covers parts and labor. Parts will be replaced or repaired at no charge, except when the equipment has failed due to lack of proper maintenance. If a part is no longer available, the part may be replaced with a similar part of equal function. Any misuse, abuse, alteration or improper installation or operations will void warranty. Determining whether a part is to be replaced or repaired is the sole decision of Brave. Brave will not provide for replacement of complete products due to defective parts. Any costs incurred due to replacement or repair of items outside of a Brave approved facility is the responsibility of the buyer and not covered under warranty. Transportation costs to and from service center and/or service calls are the responsibility of the customer.

This limited warranty specifically excludes the following; failure of parts due to damage caused by accident, fire, flood, windstorm, acts of God, applications not approved by Brave in writing, corrosion caused by chemicals, use of replacement parts which do not conform to manufacturer’s specifications, damage related to rodent and/or insect infestation and damage caused by vandalism. Additional exclusions: loss of running time, inconvenience, loss of income, or loss of use, including any implied warranty of merchantability of fitness for a specific use. Also, power equipment needs periodic parts and service to perform well, and this limited warranty does not cover instances when normal use has exhausted the life of a component or the engine.

This limited warranty does not cover any personal injury or damage to surrounding property caused by failure of any part, misuse or inability to use the product. Alteration of the product, including safety features, shall void this limited warranty.

Repair or replacement of parts does not extend the warranty period. This limited warranty gives you specific legal rights. You may also have other rights that vary by state.

Please have model number, item number and serial number on hand prior to making a warranty claim or inquiry.

For products purchased on or after January 1, 2020

BRAVE

Brave Product Registration Form

YOUR INFORMATION

Full Name:

Last First M.I.

Address:

Street Address Apartment/Unit #

City State ZIP Code

Home Phone:

Alternate Phone: _____

Email

PURCHASED FROM

Company:

Address:

Street Address Apartment/Unit #

City State ZIP Code

MODEL INFORMATION

Purchase Date

Application Type

Homeowner

Commercial

Rental

Model (i.e. BRPT704H)

Serial # (i.e. 123456)

Signature

Register your product online at www.braveproducts.com

BRAVE

A GNE BRAND

Great Northern Equipment Distributing, Inc.
20195 S. Diamond Lake Rd, Ste 100
Rogers, MN 55374
Toll-Free 800-350-8739
www.braveproducts.com
sales@braveproducts.com