

# DOSKO

# M2961000CEE

MODEL NUMBER: 2961000CE, 2961010CE,  
2961020CE, 2961060CE

SERIAL NUMBER: \_\_\_\_\_

## Owner's Manual

Instructions for Operation, Maintenance

### Stump and Root Grinder

337-13H-CE (2961000CE) 357-13HE-CE (2961010CE)  
620-20HE-CE (2961020CE) 620-25KE-CE (2961060CE)

Your Dosko grinder is intended for outdoor-use only and can be used to remove many tree stumps and exposed root systems close to ground level. By moving the blade in sweeping movements laterally over the top and front of the stump, you can gradually grind it away. Make sure you completely read and understand this manual before using the grinder for the first time.

#### WARNING

**READ and UNDERSTAND this manual completely before using the grinder!** Failure to properly operate, and maintain this grinder could result in *serious injury or death* to the operator or bystanders.

All machines have hazards associated with their operation. This stump grinder has certain special hazards, which you must be aware of. As an operator or owner you have a duty to be aware of these hazards and know preventive measures to take to avoid them. When reading this manual pay particular attention to avoiding these hazards.

In particular, be aware of the following:

- **Know location of buried electrical and other utility lines.**
- **Do not allow children or untrained adults to operate.**
- **Wear eye protection and other personal protection against flying rocks and debris.**
- **Check that cutter wheel teeth are secured, sharp and not missing.**
- **Do not operate if operator presence bar fails to stop engine upon release.**
- **Make sure no children or bystanders are within 23 meters of stump grinding operation.**
- **Protect cars, windows and other objects within 23 meters from flying debris.**
- **Be prepared for machine “kickback” when initially contacting the stump.**
- **Be aware of potential for carbon monoxide (CO) poisoning.**
- **Prevent fires/explosions from fueling.**
- **Do not attempt to perform adjustments, declog or clean unit while engine is running.**
- **Avoid burns from engine or hot exhaust.**
- **Avoid using in wet or icy conditions where falls may occur.**

Details about these hazards are found throughout the manual and are summarized at the end of the manual under “Important Safety Information.”

#### STOP!

**ADD ENGINE OIL, FUEL & BATTERY:** Your stump grinder comes fully assembled and requires only that you add engine oil to crankcase, fuel to tank, and a battery.

**INSPECT COMPONENTS:** Closely inspect to make sure no components are missing or damaged. See the “Receiving Your Unit” section for instructions on whom to contact to report missing or damaged parts.

**Any Questions, Comments, Problems or Parts Orders**  
*Call your dealer or Dosko Customer Service 1-763-428-2237*

## Hazard Signal Word Definitions





	<p>This is the safety alert symbol. It is used to alert you to potential personal injury hazards. Obey all safety messages that follow this symbol to avoid possible injury or death.</p>
	<p>DANGER (red) indicates an imminently hazardous situation which, if not avoided, will result in death or serious injury.</p>
	<p>WARNING (orange) indicates a potentially hazardous situation which, if not avoided, could result in death or serious injury.</p>
	<p>CAUTION (yellow) indicates a potentially hazardous situation which, if not avoided, may result in minor or moderate injury.</p>
	<p>CAUTION (yellow) used without the safety alert symbol indicates a potentially hazardous situation which, if not avoided, may result in property damage.</p>

fig01453

# Table of Contents

## Part I. Introduction

<b>About Your Grinder</b> .....	4
<b>Safety Decal Locations</b> .....	5
<b>Safety Decals</b> .....	6
<b>Receiving:</b>	
1. Receiving Your Unit.....	7
<b>Machine Component Identification</b> .....	8

## Part II. Operation

Operation:	
1. Pre-Start Check List & Procedures .....	9
2. Starting the Grinder.....	12
3. Stopping Engine.....	14
4. Grinding Stump.....	14
5. Refueling.....	16
6. Storing Machine.....	17

## Part III. Maintenance & Repair

<b>Maintenance</b> (To be done by owner or Rental Dealer) .....	19
1. Belt Tension Adjustment .....	21
2. Stop-Switch Adjustment .....	22
3. Setting Teeth .....	22
4. Schedule.....	24
<b>Specifications</b> .....	25

## Part IV: Important Safety Information

<b>Summary of Important Safety Information for Operation</b> .....	26
<b>Special Safety Information on Static Electricity</b> .....	29
<b>Parts Explosion</b> .....	30
<b>Wiring Diagrams</b> .....	32
<b>Warranty</b> .....	35

## About Your Grinder

Thank you for purchasing or renting your Dosko grinder!

### Owner/Operator/Renter Training

Read and follow all instructions and safety precautions presented throughout this manual. A summary of important safety information can be found at the end of the manual. Keep this manual for reference and review. **If the owner of this unit is different than the operator, give a copy of this manual to any operator to read.**

### Rental Companies

*All persons to whom you rent/loan this grinder must have access to this manual and read it.* Check the tube on the side of the unit to make sure a manual is inside. Advise all persons who will operate the machine to read it. You should also provide personal instruction on how to safely operate the grinder and remain available to answer any questions a renter/borrower might have. If videos are available, have renter watch training video.

### Engine Instructions

For detailed Engine operation and maintenance information, always refer to the engine Owner's Manual furnished with the grinder.

### Product Suitability

Before using, the user shall determine the suitability of this product for this intended use and assumes liability therein.

Your Dosko grinder can be used to remove many tree stumps and exposed root systems close to ground level. By moving the blade in sweeping movements laterally over the top and front of the stump, you can gradually grind it away. Never use a stump grinder for anything but grinding wooden tree stumps. The intended operating environment is -20°C to 40°C to 95% RH. This is representative of most outdoor conditions. Make sure you completely read and understand this manual before using the grinder for the first time. If you have any questions, contact your retail or rental dealer or Dosko Customer Service at 1-763-428-2237.

**▲ WARNING: Never attempt to cut on a slope exceeding 15°.**

Exercise caution when cutting stumps on an incline, as the machine may shift or slide unpredictably. Never attempt to cut with the machine uphill or downhill from you as it may slide toward you or you may fall toward the machine. Cut only on a slope from the side.

Dosko is constantly improving its products. The specifications outlined herein are subject to change without prior notice or obligation. The purchaser and/or user shall assume liability for any modification and/or alterations of this equipment from original design and manufacture. Any alterations shall void warranty and CE Certification.

**Contact Dosko Customer Service at 1-763-428-2237 for any questions about the appropriate use of this grinder or about optional accessories.**

### Warranty Registration

Please fill out and submit the warranty registration card so that we have your contact information for any future product literature or replacement parts you may need.

# Safety Decals

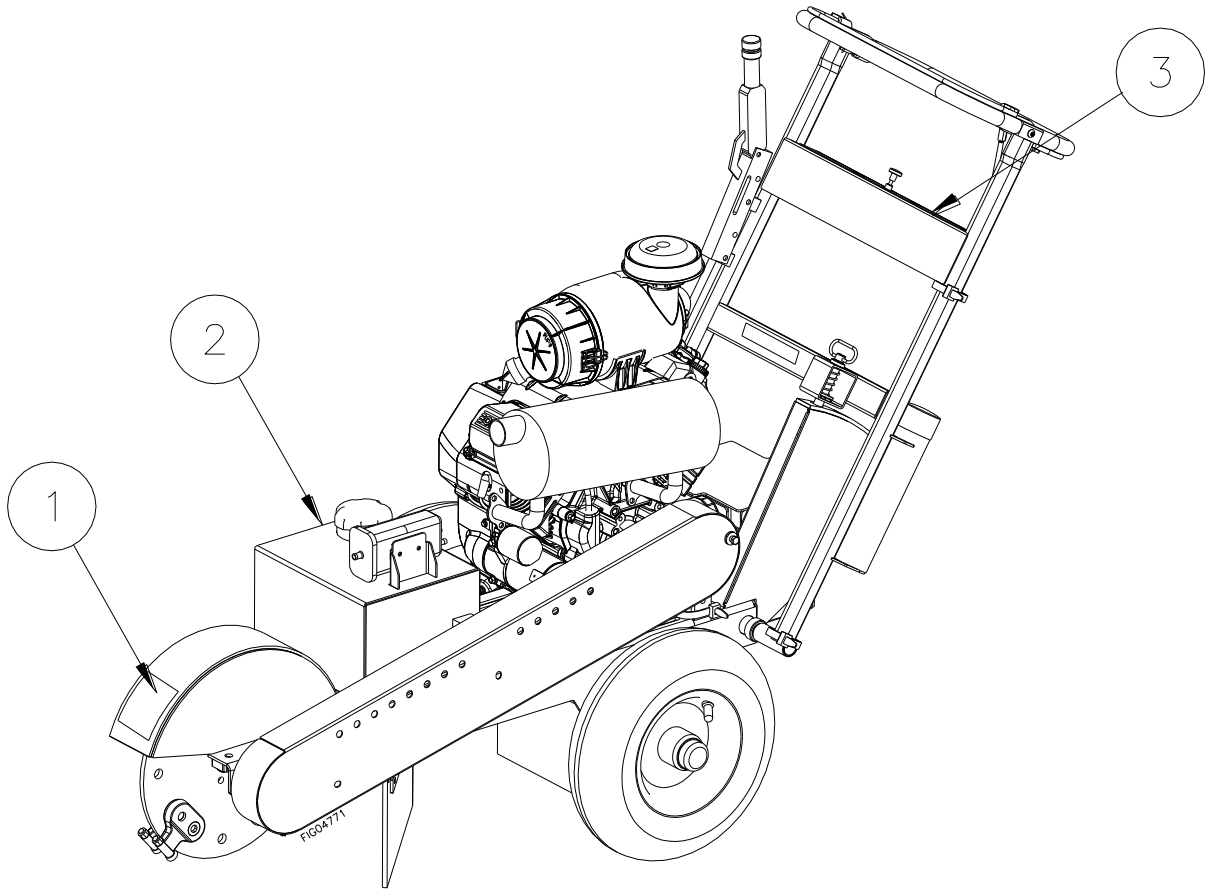

Reference #	Part #	Description	Model #
1	789537	Cut Foot Hazard	All
2	789538	Flying Debris Hazard	All
3	789661	Control Panel	337-13H-CE 357-13HE-CE 620-25KE-CE
	789663		620-20HE-CE

**⚠ WARNING**

ALWAYS make sure safety labels are in place and in good condition. If a safety label is missing or not legible, order new labels.

# Safety Decals

Ref.	Description
A	Cutting hazard to foot. Keep distance.
B	Thrown object hazard. Keep distance.
C	Wear eye protection while operating.
D	Wear ear protection while operating.
E	Wear protective footwear while operating.
F	Wear gloves while operating.
G	Push to stop. Pull to run.
H	Hazards exist. Read manual before operating.
I	Move control forward to disengage brake. Move control backward to engage brake.
J	Pull to increase choke. Push to decrease choke.
K	Pull to increase throttle. Push to decrease throttle.

**1** 789537

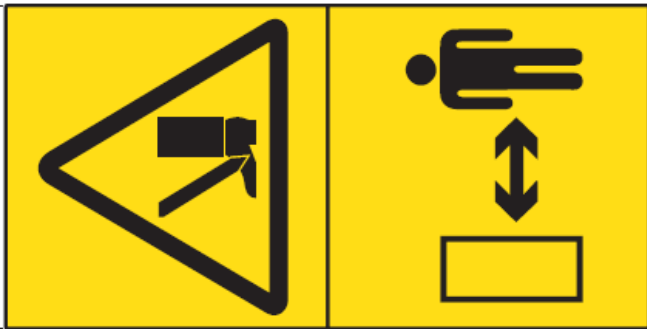

A

**2** 789538



B

I

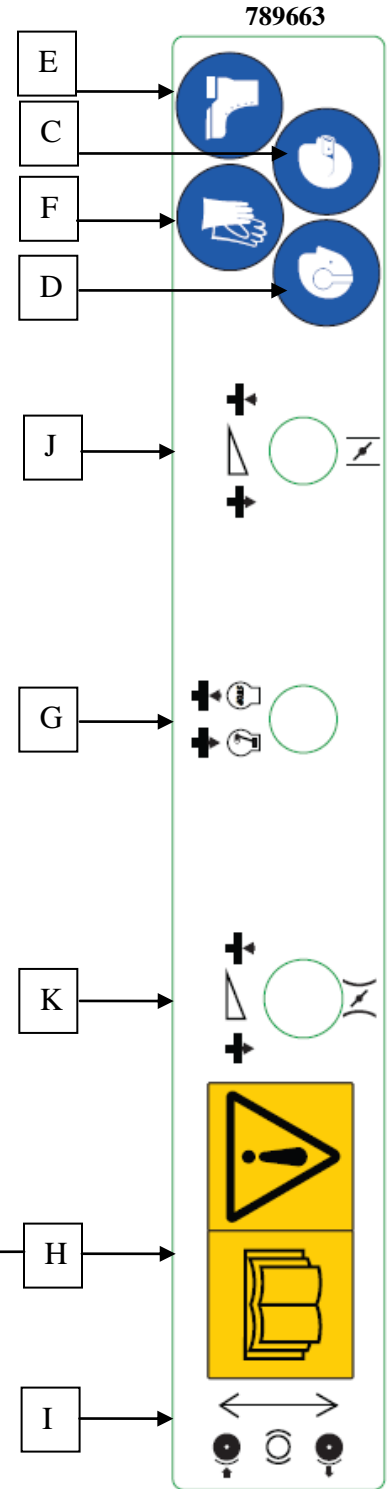
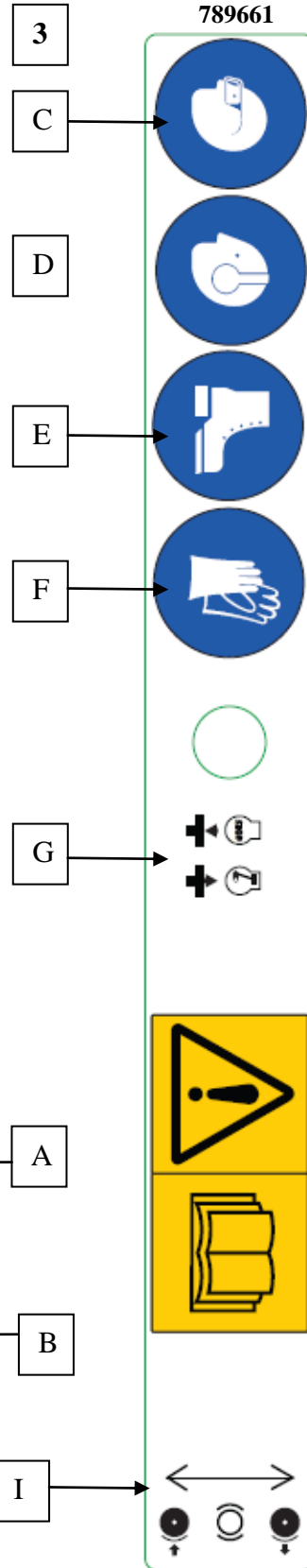

To order replacement safety labels, call Dosko Customer Service at 1-763-428-2237.

# Receiving

<b>Receiving Your Unit</b>	
<b>For all Units</b>	<p>You should inspect the grinder immediately after you receive delivery.  <i>See the “Machine Component Identification” section of this manual for a diagram of the grinder and its components.</i></p> <ul style="list-style-type: none"> <li>• If you have <i>missing</i> components, contact your rental company or Dosko Customer Service at 1-763-428-2237.</li> </ul>
<b>New Unit: Truck Delivery</b>	<p><b>Depending on your unit and model, it may have been shipped on a wooden skid, cardboard container or other appropriate method.</b></p> <ul style="list-style-type: none"> <li>• For any shipping damage, make sure the delivery driver acknowledges it and a claim is filed with the freight delivery company.  <b>Note:</b> <i>Shipping damage claims are not covered by Dosko warranty. Please contact carrier!</i></li> <li>• If any assembly is required. Separate assembly instructions will be included.</li> </ul>
<b>New Unit: From a Dealer</b>	<p><b>Your unit should have been delivered completely assembled and ready to run.</b> Read the “<i>Operation: Pre-Start Check List &amp; Procedures</i>” section (page 9), and verify that the unit has been properly “prepped” before initial use.</p>
<b>Factory Delivery</b>	<p><b>In these cases, your unit has been completely assembled, tested and pre-run. It should be ready for usage. See “Pre-Start Check List &amp; Procedures”.</b></p>

# Machine Component Identification

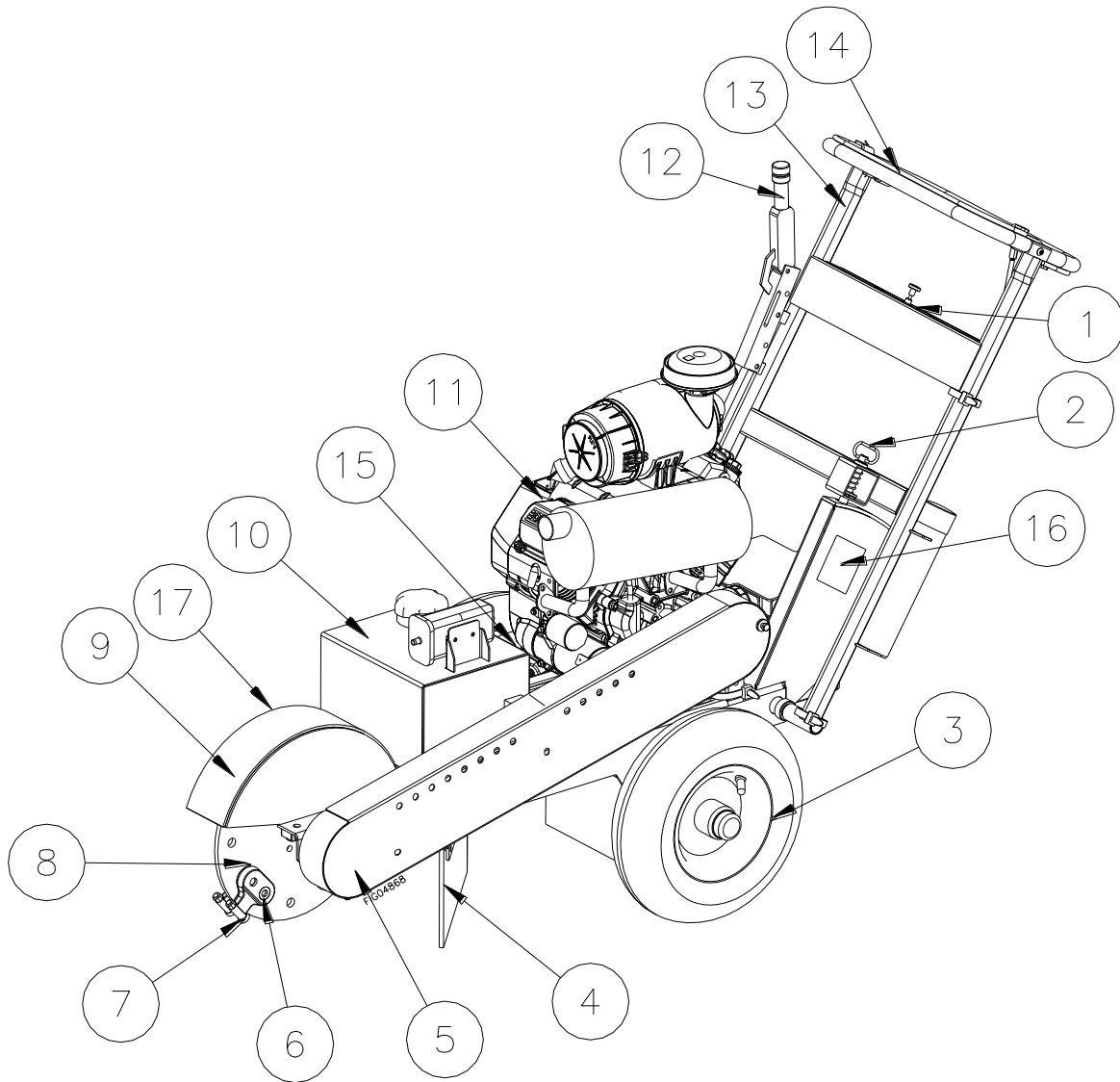

Reference #	Description	Reference #	Description
1	Control Panel	10	Gas Tank
2	Pin Adjustment Handle Bar	11	Engine
3	Tire and Hub	12	Adjustable Brake Lever
4	Discharge Flap	13	Handle Bar
5	Belt Guard	14	Operator Presence Handle Bar
6	Tooth Pocket	15	Fuel Shut Off Valve (620 only)
7	Cutting Tooth	16	Nameplate
8	Cutter Wheel Disc	17	Serial Number
9	Cutter Guard		

# Maintenance & Repair

## 1. Pre-Start Check List & Procedures

**⚠ CAUTION:**

Add engine crankcase oil. A new engine is shipped without oil. You must add the correct amount of oil to engine crankcase or engine will be damaged beyond repair.

**Before starting the engine you will want to make sure you have completed the following:**

1. **Marking underground utilities.**
2. **Checking controls.**
3. **Checking/adding oil.**
4. **Filling stump grinder gasoline tank.**
5. **Inspecting fuel system for leaks.**
6. **Adjusting handle bar.**
7. **Wearing personal protection.**
8. **Trimming stump with saw.**
9. **Clearing area of people and objects.**
10. **Working during daylight.**
11. **Battery installation.**

Each of these procedures is discussed in detail below.

<p><b>Marking Underground Utilities</b></p>	<p><b>Call your local utility company to request marking utilities 3 days before stump grinding. Trees can grow on top of and around underground wiring that was installed many years before a tree was planted.</b></p>
<p><b>Check Controls</b></p>	<p><b>Check that:</b></p> <ul style="list-style-type: none"> <li>• All guards are in place and tight.</li> <li>• Operator presence bar switch is free moving.</li> <li>• Inspect tires and rims for looseness, damage, and tire inflation.</li> </ul>
<p><b>Check Cutting Teeth</b></p>	<p>Inspect cutting teeth for tightness and sharpness. Only use factory-approved parts for repair.</p>
<p><b>Check/Add Oil</b></p>	<p><b>Check the oil level using the dipstick and add oil as needed daily.</b></p> <p>Using a funnel, add oil up to the FULL mark on the dipstick with the recommended oil type for your engine and expected ambient conditions. (See engine Owner’s Manual for oil type and capacity, and more detailed oil check/fill instructions.)</p> <p><b>⚠ WARNING: Burn Hazard</b> Never open oil fill port while engine is running. Hot oil can spray over face and body.</p>

## Operation (cont'd)

<p><b>Fill Stump Grinder Gasoline Tank</b></p>	<p>Check the gasoline level in the grinder's fuel tank. If needed, fill tank with fresh unleaded gasoline from a portable container, after first reading the warnings and instructions below.</p> <ul style="list-style-type: none"> <li>• Do NOT fill the gas tank to the top. Gasoline may spill when operating on a slope.</li> <li>• Do NOT overfill the gasoline tank. Allow at least 2.5 cm of empty space below the fill neck to allow for fuel expansion.</li> </ul> <p><b>⚠WARNING: Gasoline Fire/Explosion Hazard</b> Gasoline is highly flammable and explosive. Heat, sparks and flames can ignite gasoline vapors, which can become widespread during fueling. A flash fire ignition and/or explosion could result and cause serious injury or death. The following conditions could result in gasoline ignition/explosion:</p> <ul style="list-style-type: none"> <li>• Gas vapor collection inside enclosures.</li> <li>• Static electric sparks.</li> <li>• Sparks from electric wiring, batteries or running engines.</li> <li>• Sources of heat (such as a hot engine or exhaust).</li> <li>• Open flames, including pilot lights.</li> </ul>
<p><b>Inspect Fuel System / Check for Leaks</b></p>	<p><b>Inspect fuel system &amp; check for leaks BEFORE starting grinder.</b></p> <p><b>⚠WARNING: Fuel Leak Hazard</b> A leaking fuel line no matter how small can be the source of a fire or explosion when starting or operating the engine.</p> <ul style="list-style-type: none"> <li>• Inspect the entire fuel system. <i>Look for:</i> Signs of leaks or deterioration, chafed or spongy fuel hose, loose connections, loose or missing fuel hose clamps, damaged gasoline tank, or defective gasoline shut-off valve.</li> </ul> <p><b>If grinder is in an enclosed area and you smell gas, DO NOT start engine!</b> DO NOT light a match. DO NOT flip on an electrical switch. Exit area immediately leaving doors open and call fire department.</p>
<p><b>Adjust Handle Bar</b></p>	<p>Handle bar may have to be adjusted to accommodate for the height of stump or desired depth. When grinding above or below ground level, adjust handle bar for better control and comfort. <i>Note: Your stump grinder should not be used more than 25 cm maximum below ground</i></p>
<p><b>Personal Protection</b></p>	<p><b>Use approved protective clothing and approved protective equipment when using the machine.</b></p> <ol style="list-style-type: none"> <li>1. <b>Always wear EN166 1F safety glasses with side shields and a full-face shield.</b></li> <li>2. <b>The use of ear plugs or other hearing protection device is also recommended</b> for persons working within 4.5-6 m of the running grinder for longer than a few minutes. Hearing can be damaged from prolonged, close-range exposure to the type of noise produced by this grinder.</li> </ol>

## Operation (cont'd)

	<ol style="list-style-type: none"> <li>3. <b>Wear long pants to protect legs from sparks, hot engine and flying debris.</b></li> <li>4. <b>Never wear jewelry or loose-fitting clothing when starting or operating the grinder or any mechanical device.</b> Loose or dangling apparel, jewelry or hair can become entangled in moving parts.</li> </ol>
<b>Trim Stump with Saw</b>	Cut or trim the stump preferably to ground level using a power saw.
<b>Clear Area</b>	Dig away the earth and remove any stones near the tree stump or roots that may interfere with your work.
<b>Work During Daylight Hours</b>	Only use the machine in daylight or in well-lit conditions. Never operate the grinder after dark. Never operate the grinder in icy conditions or when there is severe weather.

### Battery Installation

Your stump grinder's engine is equipped with an electric starter (depending on model), which requires the installation of a 12-volt lawn tractor size battery (Group U1). See the Engine owner's manual for battery rating.

The battery is to be supplied by the customer and should be installed in the protective battery box located near the engine. (The inside dimensions of the battery box are 22.5 cm L x 15 cm W x 21.5 cm H.) Follow the instructions detailed below for connecting and disconnecting the battery.

#### **WARNING: Battery Hazards**

- Batteries are hazardous because they contain caustic acid, can emit explosive gases and can cause electric shock. Caution must be exercised when making connections to a battery to avoid shock and contact with the acid, and to prevent any sparking that could lead to an explosion.
- ALWAYS follow the general battery safety rules and instructions listed below.

#### **General Battery Safety Rules**

- ALWAYS use eye protection when handling batteries.
- NEVER smoke or work near sparks or other sources of ignition.
- NEVER touch both battery terminals at the same time with your hand or any non-insulated tools.
- If battery acid contacts skin or clothing, flush immediately with water and neutralize with baking soda.

#### **Connecting the Battery**

- Always connect the cables in the following sequence to avoid possible shock:
1. Find the battery cables located inside the battery box.
  2. Connect the **red** cable to the **positive (+)** terminal of the battery.
  3. Then connect the **black** cable to the **negative (-)** terminal of the battery.

## Operation (cont'd)

### Disconnecting the battery

Always disconnect cables in the following sequence to avoid possible shock.

1. First, disconnect the **black** cable from the **negative (-)** terminal of the battery.
2. Next, disconnect the **red** cable from the **positive (+)** terminal of the battery.

## 2. Starting the Grinder

After you have completed the “Pre-Start Check List & Procedures”, you are ready to start the grinder.

The following directions detail how to start the engine of your grinder.

**⚠ WARNING:**

Never attempt to use the grinder without proper protective equipment, particularly eye protection and a full-face shield.

**⚠ WARNING:**

If you have an implanted medical device, consult a physician before using this device.

### To start the grinder:

Note: For additional engine starting instructions see your Honda/Kohler engine manual.

1. Before starting you should raise or lower the handle bar to a comfortable position to accommodate the height of the stump you will be grinding.
2. Place stump machine into position with cutter wheel near the front-top edge of the stump.
3. Using lever on handle to lock the one wheel brake.

Note: For tighter brake adjustment, turn knob on top of brake lever.

**⚠ WARNING:**

**Stay in the OPERATOR POSITION while actuating controls.** Never leave grinder unattended.

4. Pull engine switch ON (some models may have an additional ON/OFF switch located on the engine).

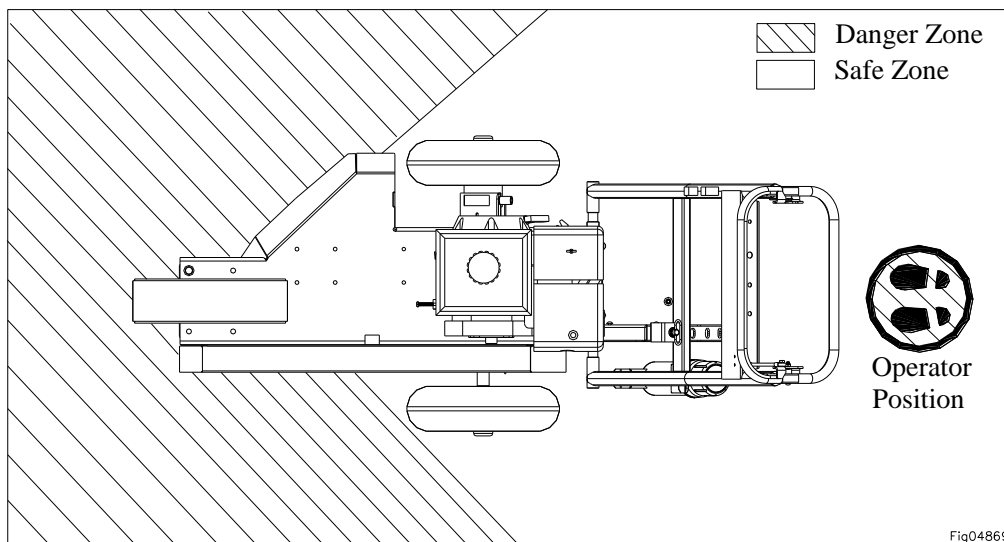

## Operation (cont'd)

5. Turn fuel valve on.
6. Pull choke if engine is cold. If engine is hot, do not use choke.
7. Grip operator presence bar and grinder handle bar together in left hand.

**▲ WARNING:**

A rotating cutter wheel is very dangerous. Stay at the controls and keep others away until you are sure the blade has come to a complete stop.

**▲ WARNING:**

**Cutter wheel immediately begins rotating when starter is pulled.** There is no clutch or gear to separately start or stop cutter wheel.

8. Since the cutter wheel starts rotating when starter is activated, press down on handle bar to lift cutter wheel off the ground.
9. **A.) Pull Start:** Rapidly pull "Start" cord (recoil starter) with right hand several times until engine starts. Allow starter cord to return slowly.
10. **B.) Electric Start:** Turn Key switch to the START position and hold until the engine starts.
11. If engine does not start, repeat steps 5-8.

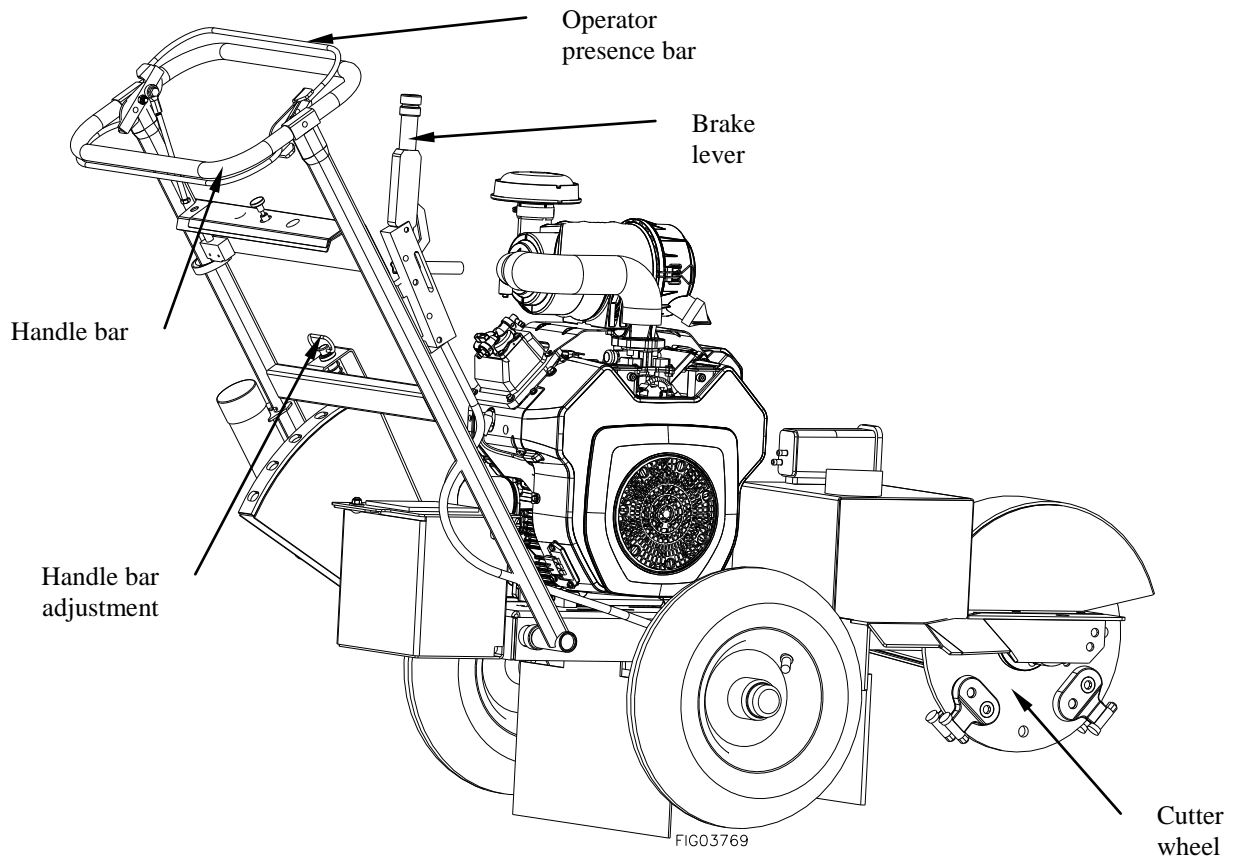

## Operation (cont'd)

### 3. Stopping the Engine

#### Stop the engine using the following steps:

1. While holding blade off ground, release the operator presence bar. Wait until the blade completely stops. Lower the blade so it is resting against the ground.
2. Make sure brake is set before leaving the controls, particularly if you are on an incline.
3. Turn engine switch to OFF position.
4. Allow the engine to cool for at least 5 minutes before releasing brake and moving to storage or transporting. A hot engine can be a fire hazard.

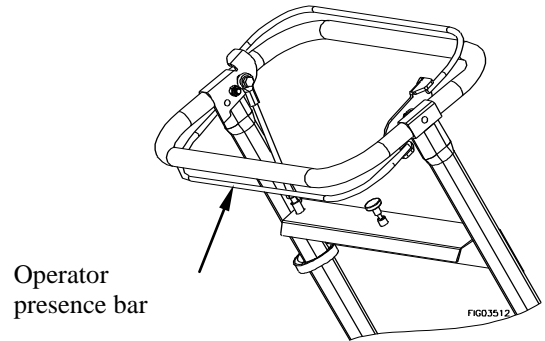

### 4. Grinding the Stump

#### **⚠ WARNING: Flying Debris Hazard**

Stones, chips, and debris can cause serious injury or property damage. Debris can fly 23 meters in any direction out of the chute. They can bounce off any fixed objects as well and hit operator, bystanders or breakable objects.

1. Set/engage the brake.
2. Pivot the grinder toward the side of the stump, then lower it approximately 1.5 to 2.5 cm into the front-top corner of the stump. Slowly pivot the cutter wheel back and forth, lowering the cutter wheel approximately 1.5 to 2.5 cm before each sweep, until you have removed the front portion of the stump to ground level.

#### **⚠ WARNING: Rotating Cutter Wheel**

Keep hands and feet away. Contact with wheel rotating teeth will cause serious personal injury.

3. Raise the cutter wheel until center of cutter wheel is just above top of stump.
4. With cutter wheel off to one side, advance the machine horizontally by releasing and resetting the brake. Advance the machine forward to engage the cutter wheel into the stump so that when swept across the stump it will remove 1.5 to 2.5 cm of stump with each sweep.
5. Sweep the cutter wheel across the stump, cutting away 1.5 to 2.5 cm of stump.
6. Advance cutter wheel 1.5 to 2.5 cm, and sweep again across stump in opposite direction.
7. Continue sweeping cutter wheel left and right across stump, advancing it before each sweep, cutting 1.5 to 2.5 cm depth of stump with each sweep.
8. Cut complete stump flush with ground, then go back and cut to further depth, if desired.

#### Chip Build-up

## Operation (cont'd)

9. When grinding larger stumps, chips may begin to build up under the wheels.
- Release brake and pull machine towards you so that the “chip pile” is directly under the cutter wheel.
  - Drop cutter wheel down on “chip pile”, material will be discharged from machine area.

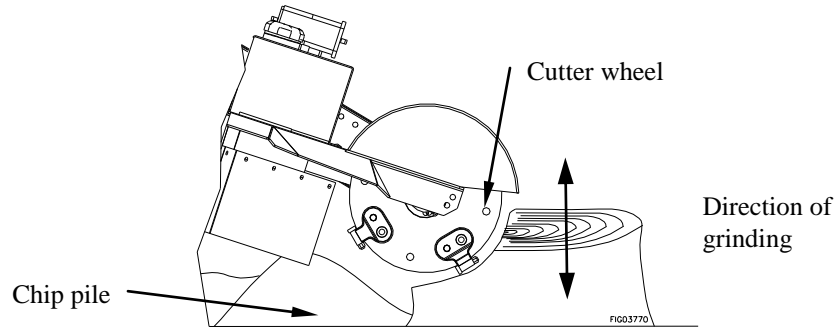

**⚠ WARNING: Flying Debris Hazard**

Stones, chips and debris can cause serious injury or property damage. Debris can fly 23 meters in any direction out of the chute and bounce off objects and hit operator, bystanders or breakable objects.

- On these larger stumps, DO NOT allow grinder wheels to drop into stump hole. If a hole is in the way of your progress, fill it with chips or change position.

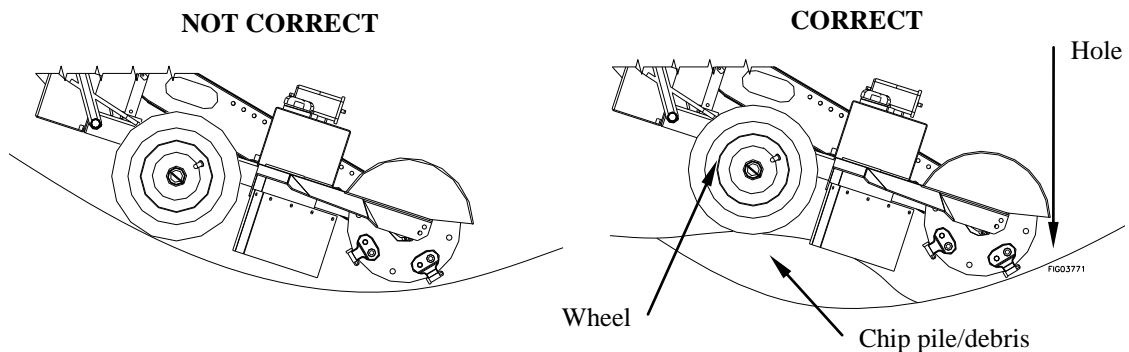

**⚠ WARNING:**

Stop engine and set brake before leaving operator's position. KEEP BRAKE ENGAGED except when changing locations. Never attempt to ride or stand on stump grinder.

10. When finished, stop the machine.
11. Pull machine away from stump, and rake chips away from stump.

## Operation (cont'd)

### 5. Refueling

1. Before removing gas cap, turn engine off and allow to cool for at least 2 minutes.

*Note:* A running or hot engine can ignite fuel.

2. Remove grinder gasoline cap.
3. Add gasoline through the fill opening:
  - Use only an UL-approved portable gasoline container to transfer the gasoline to the grinder's tank.
  - Be aware of safety warning and instructions below for avoiding static electric caused fires.

**⚠ WARNING: Static Electric Spark Hazard**

A static electric spark can explosively ignite gasoline vapor, resulting in a flash fire that could cause serious injury or death. See "Special Safety Information on Static Electricity" at end of this manual.

4. Clean up gasoline spills/splashes immediately.
  - If possible, move the grinder away from spilled gasoline on the ground.
  - Wipe up spilled gasoline, and wait 5 minutes for excess gasoline to evaporate before starting engine.
  - Gasoline soaked rags are flammable and should be disposed of properly.
  - If gasoline is spilled on your skin or clothes, change clothes and wash skin immediately.
5. Replace gasoline cap securely before starting engine.
6. Store extra gasoline in a cool, dry place in an UL-approved, tightly sealed container.
7. Filling towable units or portable containers at service stations:

Avoid static electric sparking while filling the gasoline tank:

- Never fill the grinder's gas tank directly from the fuel pump. The grinder's tank is not grounded and high velocity flow from the pump can cause static electricity build-up. Use an approved portable container to transfer gas to the grinder's tank.
- Use a portable container made of metal or conductive plastic. This is preferred because it dissipates static charge to ground more readily.
- Never fill a portable gas container while it is sitting inside a vehicle, trailer, trunk or pick-up truck bed. ALWAYS place container on the ground to be filled.
- Keep nozzle in contact with container while filling. Do not use a nozzle lock-open device.



## Operation (cont'd)

### 6. Storing the Grinder

**When you are finished using the grinder and it has cooled, you must:**

- Cool engine before storage.
- Clean the grinder.
- Inspect for worn or damaged parts.
- Choose covered storage location.
- Prevent accidental starting.
- Plan on exercising the engine at least monthly unless the grinder is prepared for long-term storage.

Detailed instructions are provided below.

<b>Cool Engine</b>	<b>Let engine cool for at least 5 minutes before storing.</b> A hot engine can be a fire hazard.
<b>Clean Grinder</b>	<b>Clean all grease, dirt, mud and other foreign matter from the machine. Touch up paint damage to prevent rust.</b>
<b>Inspect Grinder</b>	<b>Inspect the machine for worn or damaged parts and tighten any nuts or screws that may have become loose. Pay particular attention to the cutting teeth.</b>
<b>Choose a Storage Location</b>	<p><b>Store the grinder in a location that is:</b></p> <ul style="list-style-type: none"> <li>• Clean and dry.</li> <li>• Away from sources of heat, open flames, sparks, or pilot lights, even if the grinder's gas tank is empty. Residual gasoline could ignite.</li> <li>• Away from extreme high or low temperatures.</li> <li>• Cover it for extra protection.</li> </ul> <p><b>⚠WARNING:</b>  <b>If stump grinder is left in direct sunlight and exposed to extreme temperatures fuel hoses can degrade rapidly.</b></p>
<b>Remove Key</b>	<b>Remove key from starter and secure key in a safe location, or remove spark plug,</b> in order to ensure the grinder cannot be started in a storage location or by untrained persons or children.
<b>Start Grinder Every 4 Weeks</b>	<p><b>The grinder should be started regularly.</b> At least every 4 weeks, start the engine and let it run for 10 to 15 minutes.</p> <p>Monthly exercising of the grinder will dry out any moisture that has accumulated, lubricate cylinders and clean out old gas in the carburetor. Moisture, old gas and dry mechanical parts cause deterioration in stored engines.</p>

## Operation (cont'd)

### Prepare Engine for Long Term (Seasonal) Storage if Needed

**If you will not be able to start the grinder regularly, you must prepare the engine for long term storage** to prevent gum deposits from forming and causing malfunction of the engine.

Prepare engine for long term storage by:

- **Removing all gasoline** from the tank and carburetor.
- OR
- **Adding fuel stabilizer** to the gasoline (following manufacturer's instructions).

Fuel stabilizer steps:

1. Ensure gas tank is full.
2. Add fuel stabilizer to fuel tank.
3. Run engine at least 10 minutes after adding stabilizer to allow it to enter the fuel system.
4. Shut off engine.
5. Disconnect spark plug wire and remove spark plug.
6. Add 1 teaspoon oil through spark plug hole.
7. Place rag over spark plug hole and turn starter (or pull the recoil) a few times to lubricate the combustion chamber.
8. Replace spark plug, but do not reconnect the spark plug wire.

**⚠ WARNING: Gasoline Fire/Explosion Hazard**

Gasoline is highly flammable and explosive. Drain the fuel into an approved container **OUTDOORS** and far away from open flame. **NEVER** store an engine with fuel in the tank indoors or in poorly ventilated spaces where fuel vapor can come in contact with

- Static electric sparks.
- Sparks from electric wiring, batteries or running engines.
- Sources of heat (such as a hot engine or exhaust).
- Open flames, including pilot lights.

# Maintenance & Repair

## ⚠ WARNING

ALWAYS shut off the engine, make sure the engine is cool, disconnect the spark plug and positive battery terminal from the battery before cleaning, adjusting, or servicing the grinder. Make sure all guards and shields are replaced before using.

<b>Maintenance</b>	
<b>Perform Regular Maintenance</b>	<b>Perform periodic maintenance</b> as directed in this manual to keep the grinder in safe working condition.
<b>Follow Safety Rules</b>	<p><b>Read and follow these safety rules whenever you will be servicing the grinder:</b></p> <ul style="list-style-type: none"> <li>• <b>Turn off grinder.</b> Always turn off grinder and remove spark plug or spark plug wire, and disconnect positive battery terminal from battery on electric start models before working on the engine or grinder to prevent accidental starting.</li> <li>• <b>Replace guards/shields.</b> Make sure all guards and shields are replaced after servicing the grinder.</li> <li>• <b>Burns.</b> Muffler will be hot even after unit is stopped. Allow unit to cool before servicing.</li> <li>• <b>Repair.</b> Major service, including the installation or replacement of parts, should be performed only by a qualified electrical service technician. Obtain factory approved parts from Dosko Customer Service at 1-763-428-2237.</li> <li>• <b>Replacement parts.</b> If a part needs replacement, only use factory approved repair parts. Replacement parts that do not meet specifications may result in a safety hazard or poor operation of the grinder and shall void the warranty and CE certification.</li> </ul>
<b>Perform Engine Maintenance</b>	<p><b>Perform engine maintenance as specified in the engine owner's manual.</b> Engine maintenance items include:</p> <ol style="list-style-type: none"> <li>1. Oil and oil filter changing.</li> <li>2. Air filter check/replacement.</li> <li>3. Spark plug cleaning and replacement.</li> <li>4. Fuel filter check/replacement.</li> <li>5. Fuel tank cleaning.</li> </ol>
<b>Inspect Fuel System / Check for leaks</b>	<p><b>Inspect the fuel system and check for leaks on a regular basis.</b> Look for: signs of leaks or deterioration, chafed or spongy fuel hose, loose connections, loose or missing fuel hose clamps, damaged gasoline tank, or defective gasoline shut-off valve.</p>
<b>Lubricate</b>	<p><b>Cutter shaft bearings and wheel bearings should be greased.</b> The cutter shaft bearing is greased by pumping grease into zerks located on the housing of the bearing.</p>

## Maintenance & Repair (cont'd)

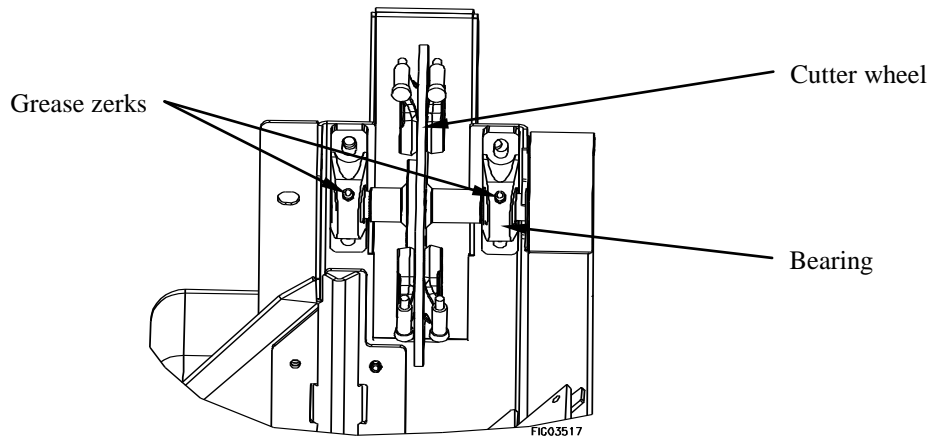

The wheels should be greased by repacking the bearings inside the wheel hub with grease.

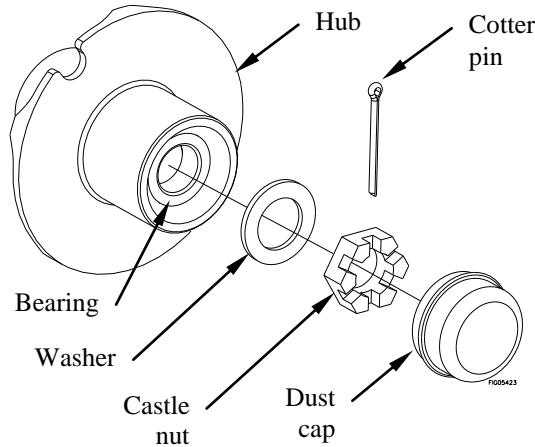

1. Remove existing cap, cotter pin, castle nut, washer, and hub off spindle.
2. Inspect inner and outer bearing and pack with grease.
3. Slide hub and washer back onto spindle.
4. Using a torque wrench, tighten the castle nut 40-54 Nm.
5. Loosen the castle nut until loose enough to turn the castle nut with your fingers.
6. Re-tighten the castle nut finger tight.
7. Reinstall cotter pin and dust cap.

Grease Specification	
Soap Type	Lithium Complex
NLGI Grade	#2
Dropping Point	230°C (446°F)
Additives	Corrosion and Oxidation inhibitors, EP optional
Viscosity Index	80 Minimum

### Check and Adjust Brake

**Check that the brake is functioning properly.**

- Lock the brake; push down on handle bar so that cutter wheel is off the ground.
- Push or pull the grinder- if the brake is loose, the wheel will rotate.

## Maintenance & Repair (cont'd)

### To adjust braking tension:

- Unscrew set screw.
- Turn knob clockwise to increase tension or counter-clockwise to decrease tension.
- Once you have set the brake to the proper tension, tighten set screw to lock adjustment knob.

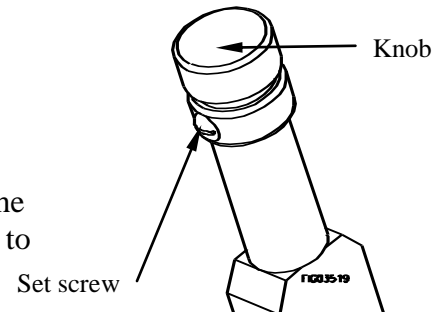

## Belt Tension Adjustment

**Note:** Belt tension and alignment are inter-related. Do not adjust one without checking the other.

1. Remove belt guard.
2. Loosen (4) engine bolts.
3. With long socket extension drive, move engine forward with rear adjusting bolt.
4. When belt tension is proper 15 to 19 Nm of tension, or 5 mm deflection, retighten all loosened bolts.
5. Reassemble belt guard.

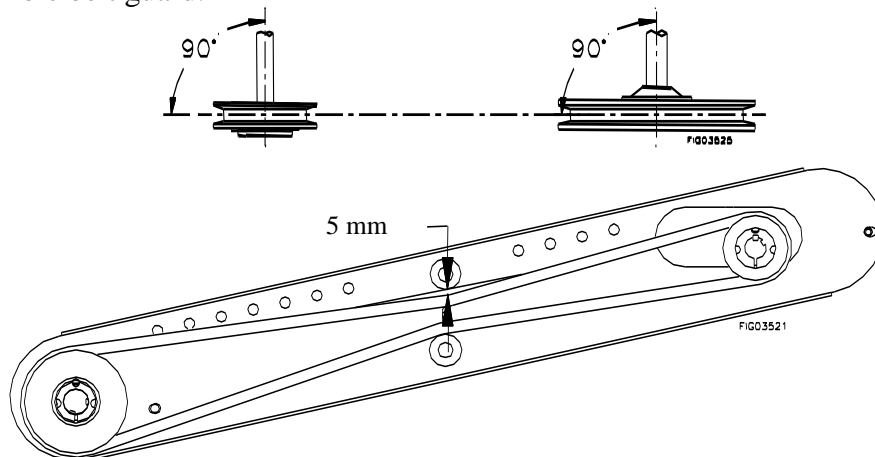

Note: New belts require a “break-in” period of approximately 10 hours. Readjustment may be necessary after “break-in”.

Note: Use only factory recommended belts. Contact your Dosko dealer.

## Maintenance & Repair (cont'd)

### Stop-Switch Adjustment

**⚠ CAUTION:**

Never attempt to alter, modify or override this switch.

**If Stop-switch ever needs to be replaced or adjusted follow the below directions.**

1. Loosen Hex Nut.
2. Turn the Linkage bolt clockwise to lower or counter-clockwise to raise the point of interaction with Stop Switch. To set the proper interaction distance, grip the Operator Presence Bar & Handle Bar together and lower the Linkage bolt onto the Switch Button until the switch button cannot be depressed any further. Then raise the linkage bolt one turn (counterclockwise).
3. Tighten Hex Nut.
4. Verify operability of stop switch before operating machine by releasing the operator presence bar next to the handle bar. You should hear a “CLICK”, signifying that the Linkage Bolt has been adjusted properly.

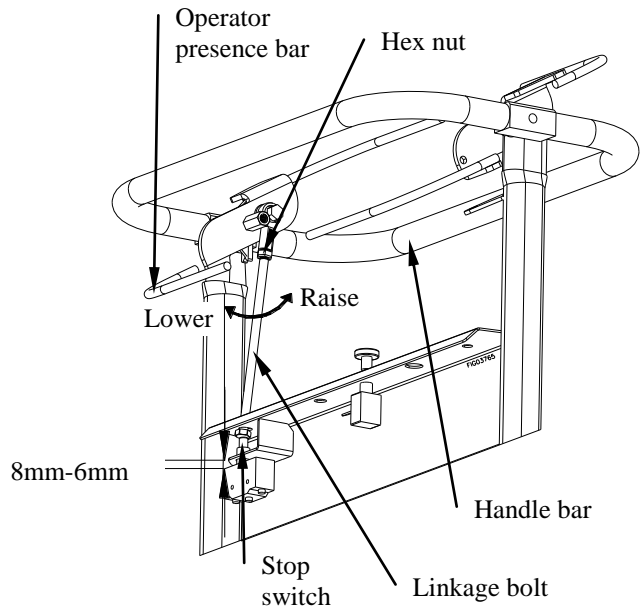

### Setting Teeth

Among the most critical elements of the stump grinder is the cutter wheel. It is also the most subject to damage and wear. In the course of grinding stumps it not only makes contact with the wood, but also encounters numerous abrasives and objects in the stump's environment, such as dirt, stones, large rocks and buried scrap.

The loss and wear of cutting teeth can significantly impair the efficiency and performance of the stump grinder. Therefore, it is important to make frequent inspections of the condition of all the cutting teeth and to sharpen or replace any damaged or worn teeth. Sharpening the teeth before excessive wear will result in longer lasting teeth and better performance.

#### Setting Teeth

#### Installing pockets

1. Locate the straight teeth and pockets on your wheel.
2. Remove 1 set of straight teeth and pockets.
3. Clean this area with a wire brush.
4. Start with a counterbored pocket. Counterbored pockets have non-threaded big holes. They go on the right-hand side of the wheel as you face the wheel. Install two low-pro pocket bolts into the counterbored pocket holes.
5. Apply anti-seize onto the threaded position of the low-pro pocket bolt.
6. Slide the counterbored pocket and low-pro pocket bolts through the holes in the wheel from the right side and thread them into the threaded holes in the

## Maintenance & Repair (cont'd)

threaded pocket. Firm up the low-pro pocket bolts until pockets are firm on the wheel. Do not tighten then down yet.

7. Rotate the wheel until you come to the next set of straight teeth. Repeat steps 2 – 6.
8. Next, replace the angle pockets (angles face away from the wheel).
9. Remove 1 set at a time or all old angle teeth and pockets at once. Clean the wheel with a wire brush.
10. Install your low-pro pocket bolt through the holes in the counterbored pocket. Apply anti-seize. Slide the low-pro pocket bolts through the holes in the wheel. Make sure the counterbored pocket is on the right hand side of the wheel. Insert the low-pro pocket bolts into the threaded pockets and tighten the pockets firmly onto the wheel. Repeat this step until all your standard angles pockets are installed.

### Installing teeth

1. If all the counterbored pockets are on the right hand side of the wheel, your tooth will go into your pocket properly. If your pockets are mounted upside down, the teeth will have a tendency to spin freely or be sloppy in the pocket. You will know this by looking at them.
2. Install your teeth with the carbide facing down. The shoulder of the tooth will meet the flat detent of the pocket and the tooth will not rotate. Thread nut onto the top portion of the tooth. Hand tighten for now. Repeat until all teeth are installed.

### Torque

1. Torque the low-pro pocket bolts to 245 – 325 Nm.
2. You will notice the slotted end of the low-pro pocket bolt is about 3 mm short of the end of the threaded pocket. This is okay. This area will fill with dirt and protect the extraction slot at the end of the low-pro pocket bolt. If you need the slot, clean out the packed dirt and use the slot to turn out the broken bolt.
3. To torque your tooth down, tighten the top lock nut until the tooth is firmly seated. (See Torque Settings table below). Double check that the tooth is firmly seated. Do not over tighten. Over tightening the nut will stretch the threads and make it impossible to ever tighten again.
4. Once the low-pro pocket bolts, teeth and nuts are seated and torqued properly, cut a few stumps. Recheck bolts and nuts to make sure they are tight and secure. Recheck frequently for the first week of use and once a week thereafter.

Torque Settings - Nuts	
500 series	15-21 Nm
700 series	27-38 Nm

When you dull or damage a cutting edge, loosen the top nut, tap the tooth down, rotate the tooth a third of a turn and tighten back up.

## Maintenance & Repair (cont'd)

### Maintenance Schedule

**⚠ CAUTION:**

Before attempting any maintenance, be sure that the engine is shut off, the key, the positive battery cable, and both spark plug wires are removed and the engine is cool to the touch!

Item (What to check or action req'd)	Daily	Each Use	10 hours	20 hours	40 hours	2x/year
Bearings, Shaft - Grease				X		
Bearings, Wheel - Grease						X
Belt Tension - Tension					X	
Bolts - Tightness			X			
Engine – See manual						
Gasoline – Amount		X				
Safety Switches – Operation		X				
Warning Decals – Legible	X					
Tires, Flaps – Condition	X					
Wires, Cables – Condition		X				
Cutter Teeth - Sharpness		X				

Safety switch and relay (equipped models only) should be replaced after 7 years of use.

**IMPORTANT:**

If a part needs replacement, only use parts that meet the manufacturer's specifications. Replacement parts that do not meet specifications may result in a safety hazard or poor operation of the grinder.

**Contact Dosko Customer Service at 1-763-428-2237  
for any questions, problems or parts orders.**

# Specifications

	<b>337-13H-CE</b>	<b>357-13HE-CE</b>	<b>620-20HE-CE</b>	<b>620-25KE-CE</b>
<b>ENGINE OPTIONS</b>				
Make	Honda	Honda	Honda	Kohler
Model	GX390UT1QAA2	GX390UT1QAE2	GX630RTXF2	CH730-0002
CC Rating	390 cc	390 cc	630 cc	721 cc
<b>GENERAL</b>				
Weight	300 lbs. (136kg)	350 lbs. (169kg)	400 lbs (181kg)	400 lbs (181kg)
Length	58" (147cm)	58" (147cm)	58" (147cm)	58" (147cm)
Height	51" (130cm)	51" (130cm)	51" (130cm)	51" (130cm)
Width	32" (81 cm)	32" (81 cm)	32" (81 cm)	32" (81 cm)
RPM Operating	3600 RPM	3600 RPM	3600 RPM	3600 RPM
Type of Fuel	Gasoline	Gasoline	Gasoline	Gasoline
Starting	Recoil	Electric	Electric	Electric
Oil Sensor	Yes	Yes	Yes	Yes
<b>CUTTER WHEEL</b>				
Diameter	14" (36cm)	14" (36cm)	14" (36cm)	14" (36cm)
Thickness	3/8" (.95cm)	3/8" (.95cm)	3/8" (.95cm)	3/8" (.95cm)
Bearings (Dia.) (2)	1-3/16" (3cm)	1-3/16" (3cm)	1-3/16" (3cm)	1-3/16" (3cm)
Teeth Pockets	Reversible	Reversible	Reversible	Reversible
Teeth (8) (Carbide Tips)	Greenteeth®	Greenteeth®	Greenteeth®	Greenteeth®
	1/2" dia. (1.27cm)	1/2" dia. (1.27cm)	3/4" dia. (1.9cm)	3/4" dia. (1.9cm)
	1/4" thick (.635cm)	1/4" thick (.635cm)	1/4" thick (.635cm)	1/4" thick (.635cm)
Disc RPM	2200 RPM	2200 RPM	2500 RPM	2500 RPM
Drive	Direct Belt Drive	Direct Belt Drive	Direct Belt Drive	Direct Belt Drive
	1 banded Gates belt	1 banded Gates belt	1 banded Gates belt	1 banded Gates belt
	3 groove power band with idler bearing belt tensioners	3 groove power band with idler bearing belt tensioners	4 groove power band with idler bearing belt tensioners	4 groove power band with idler bearing belt tensioners
<b>CUTTING CAPACITY</b>				
Above Grade	20" (51 cm)			
Below Grade	16" (41 cm)			
Stump Diameter	No Limit			
<b>NOISE AND VIBRATION DATA</b>				
Sound Pressure	94 dBA		92 dBA	103 dBA
Sound Power	104 dBA		102 dBA	113 dBA
Hand-Arm Vibration	4.32 m/s <sup>2</sup>		4.43 m/s <sup>2</sup>	4.27 m/s <sup>2</sup>
Standard Deviation	0.80 m/s <sup>2</sup>		0.75 m/s <sup>2</sup>	0.91 m/s <sup>2</sup>

# Summary of Important Safety Information

This section provides a summary of the various safety procedures and measures that have been presented throughout the manual. Keep this summary handy and refer to it to refresh your memory about how to safely use your grinder.

## **⚠ WARNING**

Carefully read and make sure you understand the following safety information before using the grinder. Improper use or maintenance of the grinder can result in ***serious injury or death*** from ***fire/explosion, carbon monoxide poisoning, lacerations, entanglement or burns***. Damage can also occur to windows, siding, vehicles and bystanders from chips and debris which can become projectiles.

## **General**

- **Read manual.** Read this Owner's Manual and the engine Owner's Manual completely before attempting to use and service the grinder. Serious injury or death can result if safety instructions are not followed.
- **Instruct operators.** The grinder owner or rental company must instruct all operators in safe grinder set-up and operation. Do not allow anyone to operate the grinder who has not read the Owner's Manual and been instructed on its safe use. Make sure Owner's manual is within the attached storage tube on the grinder.
- **Adults only.** Only trained adults should operate and service the grinder. Do not let children operate.
- **Under the influence.** Never operate, or let anyone else operate, the grinder while under the influence of alcohol, drugs or medication.
- **Intended use.** Carefully read about and understand the intended use of this grinder. Do not use for other purposes, as unforeseen hazards or equipment damage may result.
- **Controls and safety labels.** Learn how to use the machine and its controls safely. Understand and follow all safety labels.
- **Weather.** Never use in foul, bad or questionable weather, which causes a slippery ground condition.

## **Prohibition Against Modifications**

Never modify or alter the grinder in any way. Modifications can create serious safety hazards and will also void the warranty.

- **Fuel/exhaust system.** Never modify the exhaust system, fuel tanks or fuel lines. Carbon monoxide poisoning, fire or explosion could result.
- **Guards.** Do not operate grinder unless all guards and cover shields, which prevent access to moving parts and pinch points, are in place. Failure to guard the power transmission mechanisms *may result in serious injury or death*.

## **Safety – Before Use**

### **Know how to operate**

- **Review safety rules.** Before use of this grinder, review the "Operations".
- **Know how to operate.** Be thoroughly familiar with all controls and with the proper use of the equipment. Know how to stop the grinder quickly if needed.
- **Utility marking.** Call your local utility company to request marking utilities 3 days before stump grinding. Trees can grow on top of and around underground wiring that was installed many years before a tree was planted.

### **Getting Ready**

- **Flying debris.** Clear area of objects such as stones, toys, steel wire, etc. that could become caught in moving machine parts and ejected as a projectile.
- **Operate OUTSIDE only – dangerous carbon monoxide exhaust!** Grinders give off carbon monoxide exhaust, a poisonous gas that can kill. You CANNOT smell it, see it or taste it. ONLY run grinder OUTDOORS and at least 20 feet from the home, away from windows, vents and air intakes, to allow proper ventilation. If you start to feel sick, dizzy, or weak while using the grinder, shut off the engine and get to fresh air RIGHT AWAY. NEVER run grinder engine inside homes, garages, sheds or other semi-enclosed spaces. These spaces can trap poisonous gases.

## Summary of Important Safety Information (cont'd)

- **Cooling ventilation.** The grinder needs adequate, unobstructed flow of air to allow for proper cooling of engine and grinder head. Do not allow debris to accumulate and block airflow.
- **Transporting.** During transporting, take precautions to make sure stump grinder will not tip over and cause a fuel leak hazard.
- **Hot exhaust - fires.** Exhaust from engine can be extremely hot and cause fire. Position muffler at least 2 meters from combustible objects during operation.
- **Fire extinguisher.** Keep a fire extinguisher rated “ABC” by the National Fire Protection Association nearby is always recommended when using gasoline operated machinery. Keep it properly charged and be familiar with its use.

### **Personal Protective Equipment**

- **Hearing protection.** The use of ear plugs or other hearing protection device is recommended for those in close proximity to the grinder while it is operating.
- **Eye protection.** Wear ANSI approved eye protection when operating the grinder.
- **Face protection.** A helmet with a full face visor or mesh visor with protective glasses is recommended.
- **Loose/dangling.** Loose or dangling apparel, jewelry or hair can become entangled in moving parts. Never wear jewelry or loose-fitting clothing when operating the grinder.
- **Long pants.** Wear long, heavy-duty pants to protect legs from ejected materials.

### **Gasoline Safety**

Gasoline is highly flammable and explosive. You can be burned or seriously injured when handling fuel. Use extreme care when handling gasoline:

- **Fuel outdoors.** Fill fuel tank outdoors – never indoors. Gasoline vapors can ignite if they collect inside an enclosure. Explosion can result.
- **Use approved container.** NEVER pump fuel directly into engine at gas station. Static charge can build and ignite fuel. Use an UL approved fuel container to transfer gas to the engine.
- **Running/hot engine.** A running engine is hot enough to ignite fuel. Never add fuel or remove gas cap if engine is running or still hot. Stop the engine and allow cooling at least 2 minutes before adding fuel.
- **Heat/flames/sparks.** Keep sources of heat, flame or sparks away while adding fuel.
- **Don't fill to the top.** DO NOT overfill the gas tank. Allow at least 2.5 cm of empty space below the fill neck to allow for fuel expansion and operation on slopes.
- **Don't fill to the top.** DO NOT fill the gas tank to the top. Gasoline may spill when operating on a slope.
- **Replace cap.** Replace gas cap securely before starting engine.
- **Spills.** Clean up fuel spills immediately. Move grinder away from spilled fuel on the ground. Wipe fuel off engine and wait 5 minutes for excess fuel to evaporate before starting engine. Gas soaked rags should be disposed of properly.
- **On skin/clothes.** If gasoline is spilled on your skin or clothes, change clothes and wash skin immediately.
- **Inspect fuel system.** Check fuel system on a regular basis. Look for signs of leaks, deterioration, chafed or spongy fuel hose, loose or missing fuel hose clamps, damaged fuel tank or a defective fuel shut-off valve. Do not start grinder until needed repairs have been completed.
- **Gasoline storage.** Store gasoline in a cool, dry place in an UL-approved, tightly sealed container away from children.

### **Safety – During Use**

- **Safety equipment/controls.** Always operate the grinder with all safety covers, guards, and barriers in place and in good working order and all controls properly adjusted for safe operation.
- **Controls.** Stay in the OPERATOR POSITION while actuating controls.
- **Know how to stop.** Know how to stop the grinder quickly if needed by releasing the operator presence bar. If this does not work, do the following in order until unit is stopped. 1.) Push the stop button on the control panel. 2.) Use ON/OFF switch on engine (or ignition switch on electric start models). 3.) Engage full choke by flooding the engine.
- **Kickback.** Machine can experience significant “kickback” when operating or first coming into contact with the stump.
- **Slipping/falling.** Operating in wet or icy conditions could lead to losing your footing and slipping or falling.
- **Damaged.** Do not operate the grinder with damaged, missing, incorrectly adjusted or broken parts.
- **Check for gas leak before starting.** After opening gasoline valve, smell for gas before starting engine. If you smell gas, DO NOT start engine. DO NOT light a match. DO NOT flip on an electrical switch. Exit area immediately and call fire department.

## Summary of Important Safety Information (cont'd)

- **Carbon monoxide exhaust.** The running engine gives off carbon monoxide, a poisonous gas that can kill you. You CANNOT smell it, see it or taste it. If you start to feel sick, dizzy or weak while using the grinder, shut off the engine and get to fresh air RIGHT AWAY. See a doctor. You may have carbon monoxide poisoning.
- **Other exhaust dangers.** This product contains or emits chemicals known to the State of California to cause cancer, birth defects or other reproductive harm. Avoid inhalation of exhaust.
- **Smoking/sparks.** Never smoke near the running grinder, and never operate near sources of sparks or flames.
- **Hot muffler.** Never touch hot muffler or hot exhaust manifold. Exhaust and engine parts can be very hot and will burn you.
- **Machine's moving parts.** Keep hands, feet, and apparel away from drive belts, cutter wheel and other moving parts. Never remove any drive belt or guard while the unit is operating. Contact with belt or rotating teeth will cause personal injury.
- **Refueling.** DO NOT refuel the engine until it has cooled at least 2 minutes.
- **Malfunction during operation.** Always shut the machine OFF if any unusual noise or vibration occurs.
- **Vibration.** Overexposure to machine vibration on a daily basis may lead to circulatory or nerve damage.
- **Adjusting/repairing.** Always turn off grinder and remove spark plug or spark plug wire before working on the grinder to prevent accidental starting. Disconnect battery (on electric models only).

### Safety – After Use

- **Cool engine before storing.** Let engine cool for at least 5 minutes before storing. A hot engine can be a fire hazard.
- **Shut off fuel supply.** Make sure gasoline shut-off valve is in the OFF position.
- **Prevent accidental starting.** When grinder is not in use, remove key from starter (electric start engines) and secure in a safe location, or remove spark plug and disconnect positive battery terminal from battery in order to ensure that grinder cannot be started in a storage location or by untrained persons.
- **Storage location.** Store the grinder in a dry location away from sources of heat, open flames, sparks or pilot lights – such as water heaters, space heaters, furnaces, clothes dryers or other gas appliances – EVEN IF the grinder's gas tank is empty. Residual gasoline could ignite.
- **Exercise regularly.** Exercise grinder every 4 weeks to dry out moisture that accumulates in the windings. If grinder cannot be exercised on a regular basis, prepare grinder for long term storage.

### Safety – Inspection/Maintenance

Inspect and maintain your grinder on a regular basis and repair as needed to keep it in safe working condition:

- **Turn off grinder.** Always turn off grinder and remove spark plug or spark plug wire before working on the engine or grinder to prevent accidental starting. Disconnect battery (on electric models only).
- **Replace guards/shields.** Make sure all guards and shields are replaced after servicing the grinder.
- **Burns.** Do not touch hot muffler. Muffler will be hot even if unit is stopped. Allow unit to cool before servicing.
- **Replacement parts.** If a part needs replacement, only use parts that meet the manufacturer's specifications. Replacement parts that do not meet specifications may result in a safety hazard or poor operation of the grinder and will void the warranty and CE certification.

## Special Safety Information on Static Electricity

### **Static electricity and filling gasoline:**

#### **Static electricity can initiate from ungrounded gasoline tanks or containers, from flowing gasoline, and from persons carrying a static electric charge**

Static electricity on numerous occasions has explosively ignited gasoline vapors that were present during fueling processes, resulting in serious burns to nearby persons. To avoid static electricity while fueling, certain steps must be followed before and during the fueling process in order to minimize and safely dissipate static charge build-up.

#### Filling Portable Containers at Service Stations:

Use a portable container to fill grinder tank. Never fill the grinder's gas tank directly from the service station's fuel dispenser pump – the grinder's tank is not grounded and the high velocity flow of gasoline from a fuel pump can cause static electric build-up. Use an approved portable container to transfer gasoline to the grinder's tank.

- ***Use a portable container made of metal or conductive plastic.*** It will dissipate charge to ground more readily.
- ***Fill container on the ground.*** Never fill the portable gas container while it is sitting inside a vehicle, trailer, trunk or pick-up truck bed. ALWAYS place container on the ground to be filled.
- ***Touch a grounded metal object before starting.*** Always dissipate static charge from your body before beginning the fueling process by touching a grounded metal object at a safe distance away from fuel sources.
- ***Keep nozzle in contact with container.*** Keep fuel dispenser nozzle in contact with the portable container at all times while filling at a service station. Do not use the nozzle lock-open device on the dispenser hose.

#### About static electricity and fueling

Many common objects can accumulate and retain a static electric charge. Objects made of non-conductive materials (e.g. plastics) easily accumulate and retain static electric charge, as can objects made of conductive material (e.g. metal, water) if they are not electrically grounded. The static electric charge on an object, such as a human body or plastic fuel tank/container, can reach as high as several thousand volts!

A static electric spark can be generated if the static electric charge stored on an object “jumps” to another, less charged object. Such a spark can ignite invisible gasoline vapors that are present during fueling situations.

#### Typical sources of static electric hazards during fueling

The following objects can accumulate a static electric charge and cause an ignition spark in typical fueling situations:

- Ungrounded tanks/containers. Any ungrounded fuel tank or container can accumulate a static electric charge as a result of contact with other objects or friction during transportation. This static electricity can discharge as a spark to the grounded gasoline dispenser nozzle, as the nozzle is first brought close to the tank/container at the beginning of the fueling process.
- Flowing gasoline. Most people are not aware that gasoline accumulates static electric charge while flowing through a hose or pipe. This charge then transfers to and accumulates in the gas tank or container that is being filled. The total amount of charge accumulation depends on the amount of gas pumped into the container, the speed with which it is pumped, and whether or not the tank/container is grounded. If sufficient static electric charge accumulates in the fuel tank or container during the fueling process, the tank/container may discharge a spark to the grounded gasoline dispenser nozzle.
- Persons. A person dispensing the gasoline can carry a static electric charge on their body, typically resulting from contact with their car seat or electronics. The static electricity can discharge as a spark between that person's hand and either the grounded dispenser nozzle or the fuel tank opening.

# M2961000CE Exploded View – Rev E

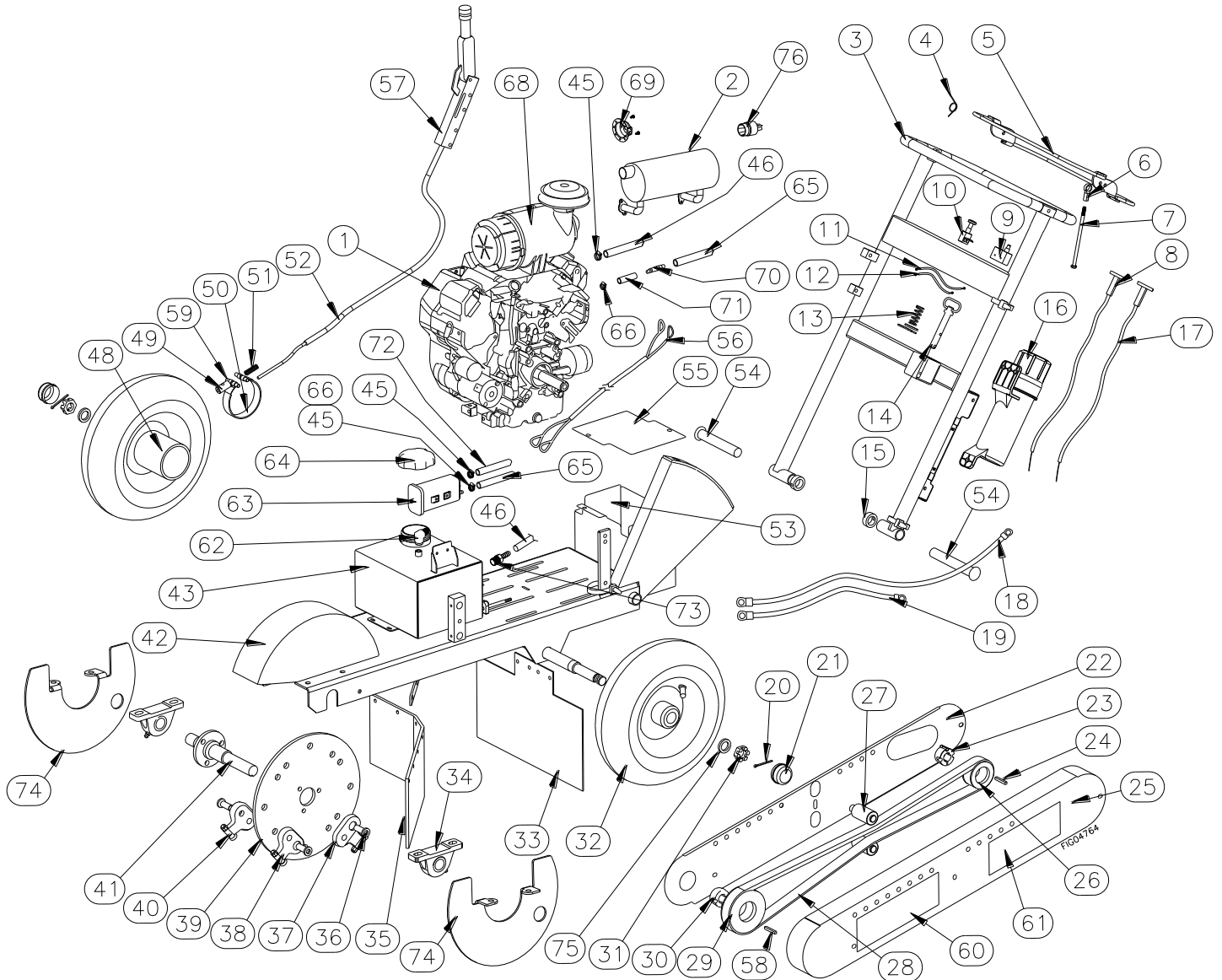

### Personal Protection Equipment (not shown):

174630	Reusable corded earplugs	1
174653	Face shield	1
174690	Safety eyewear	1
8467	Safety gloves	1

# M2961000CE Parts List – Rev E

Item	Part #	Description	Qty	Model
1	601091	GX390 Honda	1	337-13H-CE
	601092	GX390 Estart Honda		357-13HE-CE
	783896	GX630 Honda		620-20HE-CE
	784704	25hp Kohler		620-25KE-CE
2	785692	Muffler	1	620-20HE-CE
	784059	Muffler canister		620-25KE-CE
3	785138	Handle	1	All
4	783924	Spring	1	All
5	783493	Operator presence handle bar	1	All
6	782399	Ball joint rod	1	All
7	783945	Linkage	1	All
8	784207	Throttle cable	1	620-20HE-CE
9	783545	Microswitch	1	All
	783769	Microswitch bracket		
10	786073	On/off switch w/ black knob	1	337-13H-CE
	786074			357-13HE-CE
				620-20HE-CE
	783546			620-25KE-CE
11	783285	8" Lead wire, green	1	All
12	783284	6" Lead wire, green	1	620-25KE-CE
13	783539	2" Spring	1	All
14	783774	4" Hitch pin	1	All
15	783538	Lock collar	2	All
16	783815	Manual Tube	1	All
17	784208	Choke cable	1	620-20HE-CE
18	32839	43" Battery cable (red)	1	357-13HE-CE 620-20HE-CE 620-25KE-CE
19	777108	24" Battery cable (blk)	1	357-13HE-CE 620-20HE-CE 620-25KE-CE
20	82140	Cotter pin	2	All
21	124A	Dust cap	2	All
22	785134	Inner belt guard	1	All
23	783563	Bushing, 1"	1	337-13H-CE
	784053	Bushing, 1-1/8"		357-13HE-CE 620-20HE-CE 620-25KE-CE
24	82143	1/4" x 1-3/4" key	1	All
25	785136	Outer belt guard	1	All
26	783562	3" Sheave, 3 groove	1	337-13H-CE
	784052	3.35" Sheave, 4 groove		357-13HE-CE 620-20HE-CE 620-25KE-CE
27	783552	Idler bearing	2	All
28	783561	Belt, 3 groove	1	337-13H-CE
	784056	Belt, 4 groove		357-13HE-CE 620-20HE-CE 620-25KE-CE
29	783564	4.75" Sheave, 3 groove	1	337-13H-CE
	784054	4.75" Sheave, 4 groove		357-13HE-CE 620-20HE-CE 620-25KE-CE
30	783565	Bushing, 1-3/16"	1	All
31	777124	1" Slotted nut	2	All
32	777799	Wheel	1	All
33	783550	End flap	1	All
34	783556	Pillow block bearing	2	All
35	783551	Chute flap	1	All
36	783555	Lo-pro pocket bolt	8	All
37	784165	500 series straight pocket	4	337-13H-CE
	784166	700 series straight pocket		357-13HE-CE 620-20HE-CE 620-25KE-CE

Item	Part #	Description	Qty	Model
37	784165	500 series straight pocket	4	337-13H-CE
	784166	700 series straight pocket		357-13HE-CE 620-20HE-CE 620-25KE-CE
38	783557	500 series tooth	8	337-13H-CE
	792160	700 series tooth		357-13HE-CE 620-20HE-CE 620-25KE-CE
39	783480	Cutter wheel, 14"	1	All
40	783554	500 series angled pocket	4	337-13H-CE
	783559	700 series angled pocket		357-13HE-CE 620-20HE-CE 620-25KE-CE
41	785079	Cutter shaft	1	All
42	783435	Frame	1	337-13H-CE
	784041			357-13HE-CE 620-20HE-CE 620-25KE-CE
43	785581	Fuel tank	1	620-20HE-CE 620-25KE-CE
45	777834	1/4" Hose clamp	4	620-20HE-CE
			5	620-25KE-CE
46	777345	1/4" Fuel hose	50"	620-20HE-CE
			27"	620-25KE-CE
48	783484	Wheel & brake drum	1	All
49	783570	Cable clamp	1	All
50	783567	4" Brake band	1	All
51	783569	1.5" Spring	1	All
52	783295	Brake cable	1	All
53	785128	Battery box	1	357-13HE-CE 620-20HE-CE 620-25KE-CE
54	37878	1" x 6" clevis pin	2	All
55	785130	Battery box top	1	357-13HE-CE 620-20HE-CE 620-25KE-CE
56	786072	Wire harness	1	337-13H-CE
	783283			357-13HE-CE 620-20HE-CE 620-25KE-CE
57	783547	Brake lever assembly	1	All
58	82143	1/4" x 1-3/4" key	1	620-25KE-CE
59	783568	Floating pin	2	All
60	783543	Dosko decal	1	All
61	783544	Stump grinder decal	1	All
62	783212	1/4" x 1/4" hose barb elbow	1	620-20HE-CE 620-25KE-CE
63	781922	Carbon canister	1	620-20HE-CE 620-25KE-CE
64	784769	Sealed fuel cap	1	620-20HE-CE 620-25KE-CE
65	785755	3/8" fuel line	60"	620-20HE-CE
	777345	1/4" fuel line	35"	620-25KE-CE
66	30745	3/8" hose clamp	2	620-20HE-CE
67	782319	Purge port cap	1	620-25KE-CE
68	785411	Air cleaner for GX630	1	620-20HE-CE
69	785508	Exhaust deflector w/ screws	1	337-13H-CE 357-13HE-CE
70	785769	1/4" x 3/16" hose mender	1	620-25KE-CE
71	785337	4.5mm fuel line	2"	620-25KE-CE
72	777345	1/4" fuel line	11"	All
73	777340	1/4" MPT x 1/4" hose barb	1	620-20HE-CE 620-25KE-CE
74	790895	Cutter Guard	2	All
75	781341	Spark Arrestor	1	620-20HE-CE
76	778844	Axle Washer	2	All

# Wiring Diagram 337-13H-CE, 357-13HE-CE, 620-20HE-CE

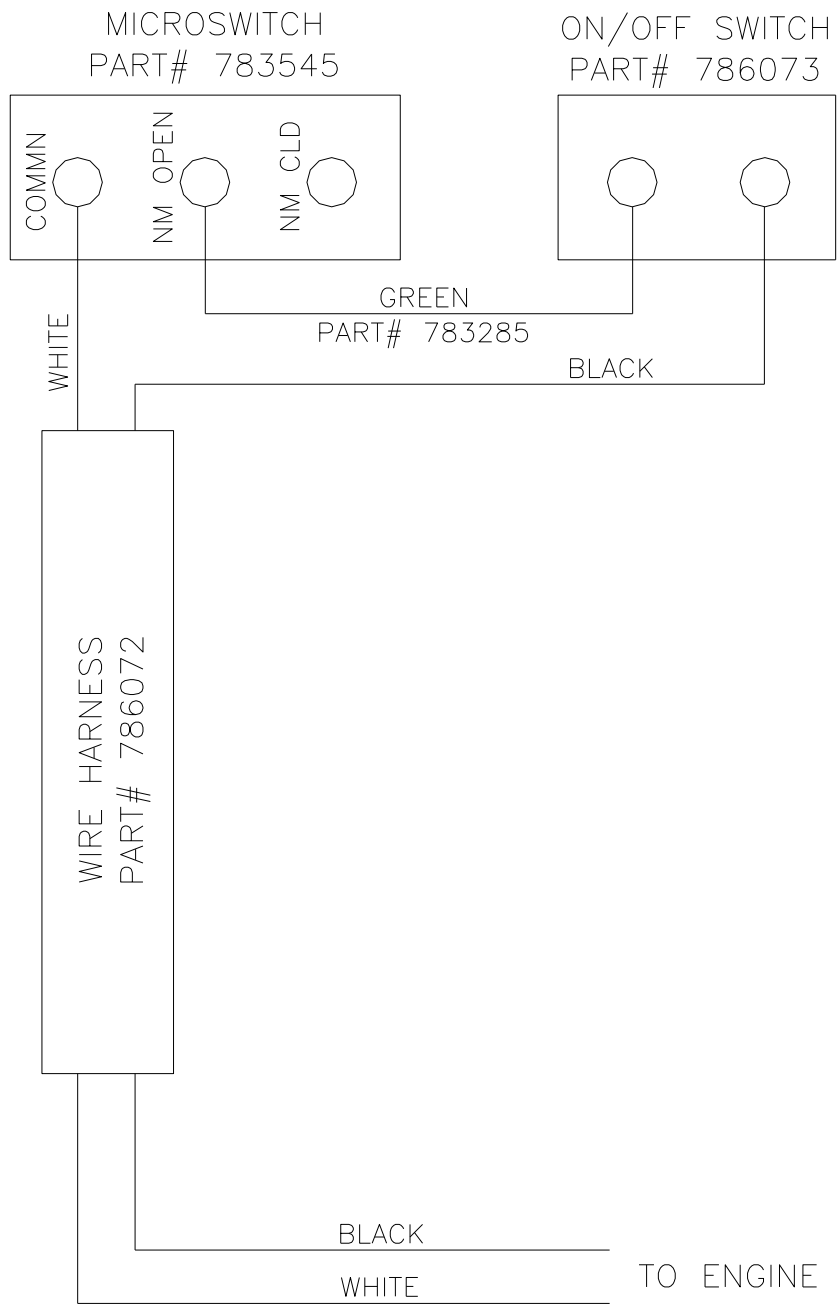
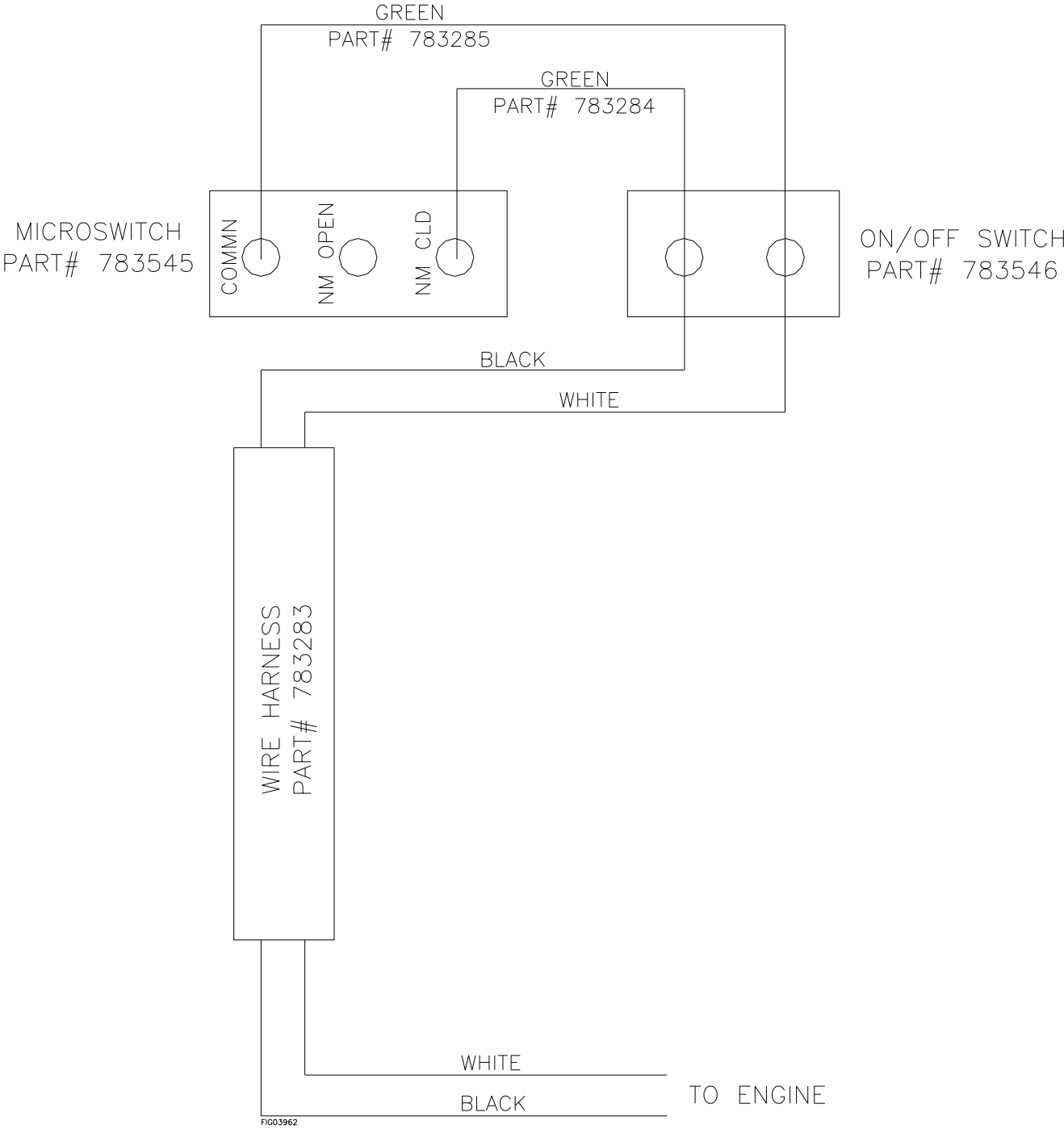

FIG03961

# Wiring Diagram 620-25KE-CE



*This page is intentionally left blank*

# Limited Warranty Policy

**Dear Valued Customer:**

The Dosko product you just purchased is built with the finest material and craftsmanship. Use this product properly and enjoy the benefits from its high performance. By purchasing a Dosko product, you show a desire for quality and durability. Like all mechanical equipment this unit requires a due amount of care. Treat this unit like the high quality piece of machinery it is. Neglect and improper handling may impair its performance.

Thoroughly read the instructions and understand the operation before using your product. Always contact Dosko Product Support at 1-866-298-3659 prior to having any service or warranty work performed, as some services performed by parties other than Dosko approved service centers may void this warranty. This limited warranty is in lieu of any other warranty expressed or implied, written or oral and Dosko assumes no other responsibility or liability outside that expressed within this limited warranty.

**Limited Warranty for Stump Grinder Models:**

200-6H	357-13HE	691SP-20HE
270-9H	620-20HE	691SP-25KE
337-13H	620-25KE	

	Consumer Warranty Period	Commercial Warranty Period
<b>Weldments</b>	2 years from date of purchase by user	2 year from date of purchase by user
<b>Hydraulic Motor, Valves, Pumps</b>	2 years from date of purchase by user	1 year from date of purchase by user
<b>Wear Parts</b>	In addition to the normal warranty, Dosko shall warrant some normal wear items from defects in material or workmanship for a period of 30 days from the date of purchase by user. Normal wear items covered under this warranty are limited to: tires, belts, grease zerks, hoses, bearings, hoses, teeth, pockets, bolts, clutches, switches, wires, cables. Routine maintenance items such as lubricants, clutch adjustments, tune ups are not covered under warranty.	
<b>Engines</b>	The engine warranty is covered under the terms and conditions as outlined by the engine manufactures warranty contained herein and is the sole responsibility of the engine manufacturer. Normal engine maintenance such as spark plugs, oil changes, air filters, adjustments, fuel system cleaning and obstruction due to build up is not covered by this Dosko limited warranty.	

“**Consumer use**” means personal residential household use by a consumer. “**Commercial use**” means all other uses, including, but not limited to, use for commercial, income producing or rental purposes or when purchased by a business.

This limited warranty applies to the original purchaser of the equipment (verification of purchase, in the form of a receipt, is the responsibility of the buyer), is non-transferable, and covers parts and labor. Parts will be replaced or repaired at no charge, except when the equipment has failed due to lack of proper maintenance. If a part is no longer available, the part may be replaced with a similar part of equal function. Any misuse, abuse, alteration or improper installation or operations will void warranty. Determining whether a part is to be replaced or repaired is the sole decision of Dosko. Dosko will not provide for replacement of complete products due to defective parts. Any costs incurred due to replacement or repair of items outside of a Dosko approved facility is the responsibility of the buyer and not covered under warranty. Transportation costs to and from service center and/or service calls are the responsibility of the customer.

This limited warranty specifically excludes the following; failure of parts due to damage caused by accident, fire, flood, windstorm, acts of God, applications not approved by Dosko in writing, corrosion caused by chemicals, use of replacement parts which do not conform to manufacturer’s specifications, damage related to rodent and/or insect infestation and damage caused by vandalism. Additional exclusions: loss of running time, inconvenience, loss of income, or loss of use, including any implied warranty of merchantability of fitness for a specific use. Also, outdoor power equipment needs periodic parts and service to perform well, and this limited warranty does not cover instances when normal use has exhausted the life of a component or the engine.

This limited warranty does not cover any personal injury or damage to surrounding property caused by failure of any part, misuse or inability to use the product. Alteration of the product, including safety features, shall void this limited warranty.

Repair or replacement of parts does not extend the warranty period. This limited warranty gives you specific legal rights. You may also have other rights that vary by state.

Please have model number, item number and serial number on hand prior to making a warranty claim or inquiry.

# DOSKO

Great Northern Equipment Distributing Inc.  
20195 S. Diamond Lake Rd, Ste 100  
Rogers, MN 55374  
Made in USA

Authorized Representative

QNET BV  
Hommerterweg 286  
6436 AM Amstenrade  
The Netherlands